

 Cite this: *RSC Adv.*, 2021, 11, 24474

 Received 2nd April 2021
 Accepted 17th June 2021

DOI: 10.1039/d1ra02606b

rsc.li/rsc-advances

Recent advances in intermolecular 1,2-difunctionalization of alkenes involving trifluoromethylthiolation

 Li Yan-mei,^{*a} Fu Jin-feng,^a He Long-qiang,^a Li Wei-na^a and Esmail Vessally ^b

Trifluoromethylthiolative difunctionalization of alkenes, a cheap and abundant feedstock, which installs a trifluoromethylthiol (SCF₃) group and another unique functional group across the carbon–carbon double bonds, provides an ideal strategy for the preparation of β-functionalized alkyl trifluoromethyl sulfides and has become a hot topic recently. This review aims to summarize the major progress in this exciting research area, with particular emphasis on the mechanistic aspects of the reaction pathways.

1. Introduction

Organofluorine compounds play an exceptionally important role in the field of medicinal chemistry and related areas due to the beneficial effects of the fluorine moiety on the physicochemical and biological properties of molecules.^{1,2} Intriguingly, up to 25% of the current blockbuster drugs³ and about 40% of contemporary agrochemicals⁴ contain at least one fluorine atom or a fluorinated functional group in their structures. The trifluoromethylthiol (–SCF₃) group is one of the most important fluorine-containing substituents, which is found in many bioactive compounds and commercialized drugs, such as toltrazuril, tiflorex, and fipronil.⁵ Thus, the introduction of this functionality into organic molecules has gained increasing interest from synthetic organic chemists and significant progress has been achieved in this area over the past few years.⁶ On the other hand, the direct vicinal difunctionalization of alkenes has recently become a powerful and viable strategy for quickly increasing molecular complexity *via* concomitant introduction of two functional groups onto the carbon–carbon double bond within a single click.^{7,8} In this context, some important trifluoromethylthiolative difunctionalization reactions such as carbo-, halo-, amino-, thio-, seleno-, phosphono-, and oxytrifluoromethylthiolation of alkenes have been developed to afford β-functionalized alkyl trifluoromethyl sulfide derivatives in one-pot with high selectivity (Fig. 1). Despite the significant advances in this exciting research topic over the past few years, no comprehensive and insightful review has appeared in the literature until now. Thus, it is an appropriate time to summarize those achievements. In connection with our recent reviews on organofluorine^{9f,9} and organosulfur chemistry,¹⁰

within this review, we will summarize recent discoveries and accomplishments in the arena of intermolecular trifluoromethylthiolative difunctionalization of alkenes, with the aim of stimulating further research in this hot research area.

2. Carbo-trifluoromethylthiolation

In 2017, Liu and co-workers reported a unique visible-light-driven trifluoromethylthiotrifluoromethylation of alkenes **1** using Langlois reagent (CF₃SO₂Na) as a solid and easily-handleable source of CF₃ and *N*-trifluoromethylthiosaccharin **2** as a commercially available SCF₃ source.¹¹ The reaction was carried out in the presence of 9-mesityl-10-methylacridinium (Mes-Acr⁺) as an organic photoredox catalyst at room temperature under constant irradiation by a white LED, tolerated various terminal and internal aliphatic alkenes and afforded the corresponding vicinal trifluoromethylthio-trifluoromethylated compounds **3** in good yields and excellent levels of diastereoselectivity, in which the trifluoromethyl group predominantly added to the less sterically hindered end of the double bond (Scheme 1). Interestingly, by simply replacing *N*-trifluoromethylthiosaccharin reagent with *N*-chlorophthalimide and *N*-bromophthalimide, respectively, the optimized reaction conditions could be applied to the vicinal chlorotrifluoromethylation and bromotrifluoromethylation of alkenes. The authors evoked a reaction mechanism initiated by single electron oxidation of CF₃SO₂Na by the photoexcited Mes-Acr⁺* to yield a CF₃ radical and an acridine radical **A**. Next, the CF₃ radical selectively attacks the less hindered end of alkene **1** to form the β-trifluoromethyl carbon-centered radical **B** that, after coupling with the *in situ* generated SCF₃ radical, affords the expected products **3**. Finally, the nitrogen-centered radical **C**, which was generated through homolytic N–S bond cleavage of reagent **2**, oxidizes the acridine radical by a single electron transfer (SET) process to regenerate the photocatalyst (Scheme 2). In a related investigation, Jiang and Yi along with their

^aInstitute of Chemical Industry and Environmental Engineering, Jiaozuo University, Jiaozuo, Henan 454000, China. E-mail: liyanmei0163@126.com

^bDepartment of Chemistry, Payame Noor University, P.O. Box 19395-3697, Tehran, Iran



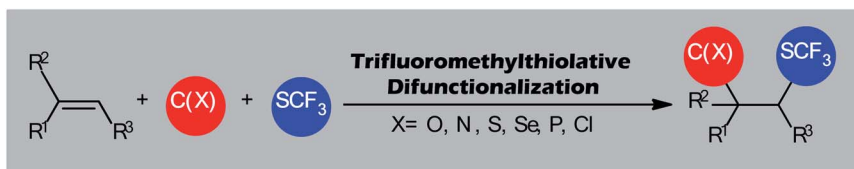
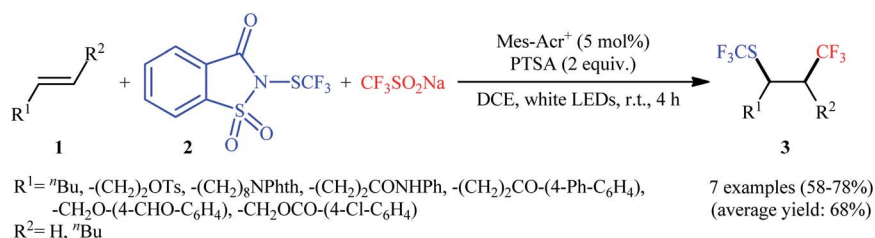
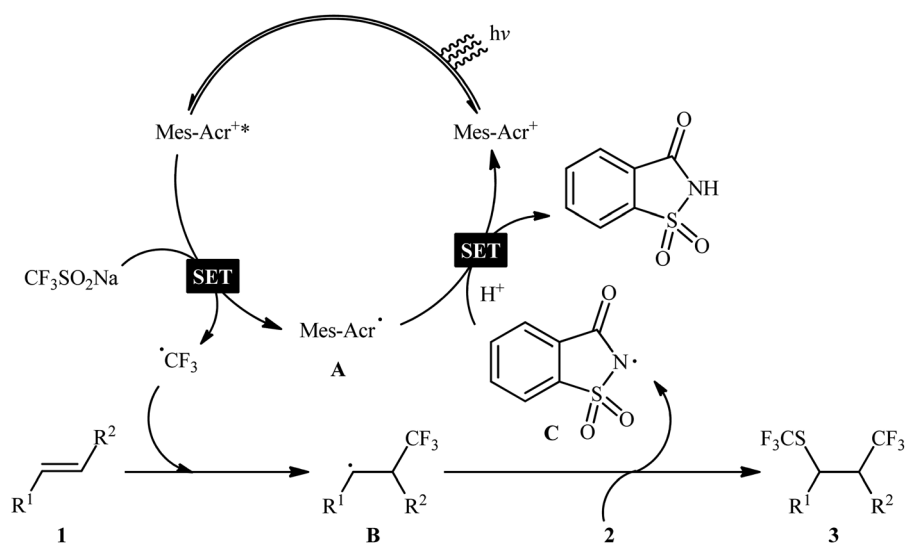

Fig. 1 Intermolecular trifluoromethylthiolative difunctionalization of alkenes.

Scheme 1 Visible-light-driven trifluoromethylthiotrifluoromethylation of alkenes **1** with CF_3SO_2Na and *N*-trifluoromethylthiosaccharin **2** reported by Liu.Scheme 2 Reaction mechanism for trifluoromethylthiotrifluoromethylation of alkenes **1**.

colleagues developed an efficient conversion of a diverse range of mono-, di-, and tri-substituted alkenes to the corresponding 1-CF₃-2-SCF₃-alkanes, using Langlois reagent as both the trifluoromethylating and trifluoromethylthiolating agent under

a dual visible light photoredox/transition metal catalytic system.¹²

In this context, Liang's research group developed an operationally simple method for the direct trifluoromethylthiolation-difluoroalkylation of alkenes employing (bpy)CuSCF₃ (bpy =

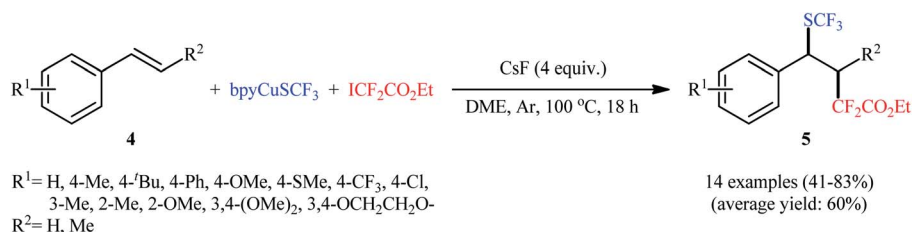
Scheme 3 Liang's trifluoromethylselenenolation-difluoroalkylation of styrenes **4**.

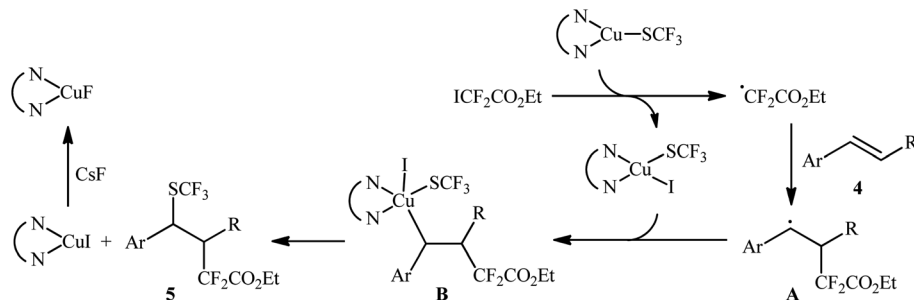

Scheme 4 The proposed pathway for the formation of trifluoromethylthio-difluoroalkylated products 5.

2,2'-bipyridine) and ethyl iododifluoroacetate (ICF₂CO₂Et) as trifluoromethylthiolating and difluoroalkylating reagents, respectively.¹³ Various styrene derivatives **4** slowly reacted with these reagents to afford the corresponding trifluoromethylthio-difluoroalkylated products **5** in moderate to high yields when running the reaction in the presence of CsF in DME at 100 °C (Scheme 3). Similar to trifluoromethylthiolation-difluoroalkylation, the method could also be used for trifluoromethylselenolation-difluoroalkylation using (bpy)CuSeCF₃. However, aliphatic alkenes were not effective in this system. According to the mechanism proposed by the authors, (bpy)CuSCF₃ not only serves as a SCF₃ source, but also acts as a free-radical initiator of ICF₂CO₂Et (Scheme 4). Concurrently, a similar alkylative trifluoromethylthiolation of alkenes (aromatic and aliphatic) with NMe₄SCN and alkyl halides (bromides, iodides) in the presence of CuI/binap under the

condition of visible light was reported by Peters *et al.*¹⁴ A number of primary, secondary, and tertiary alkyl halides were used to establish the general applicability of this methodology. However, the presence of an electron-withdrawing substituent on the substrates is crucial for the success of this reaction.

An attractive contribution to this field was reported by Chen *et al.*,¹⁵ who developed a convenient arylyative trifluoromethylthiolation of styrenes **6** with arenediazonium salts **7** and copper(i) trifluoromethylthiolate (CuSCF₃) to generate valuable (1,2-diarylethyl)(trifluoromethyl)sulfanes **8** (Scheme 5). Both electron-donating and electron-deficient functional groups (*e.g.*, F, Cl, Br, I, OMe, NO₂, CN, CO₂H, and NHAc) on both substrates were well tolerated by this protocol. Thus, this procedure provides potential opportunities for further manipulation of the products. Heteroaromatic diazonium salts were also compatible substrates in this transformation. However, the

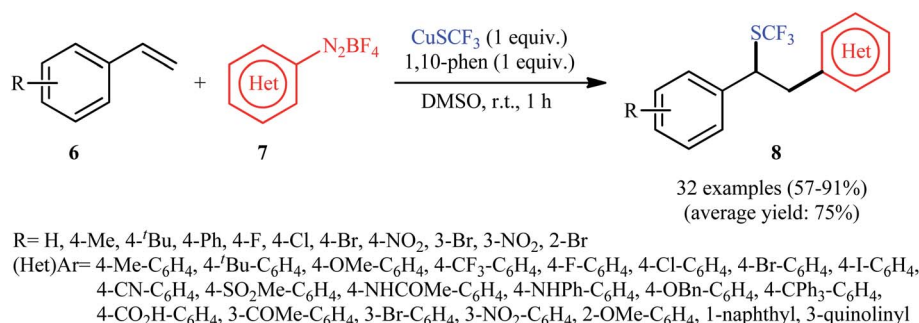

Scheme 5 Arylyative trifluoromethylthiolation of styrenes **6** with arenediazonium salts **7** and CuSCF₃.

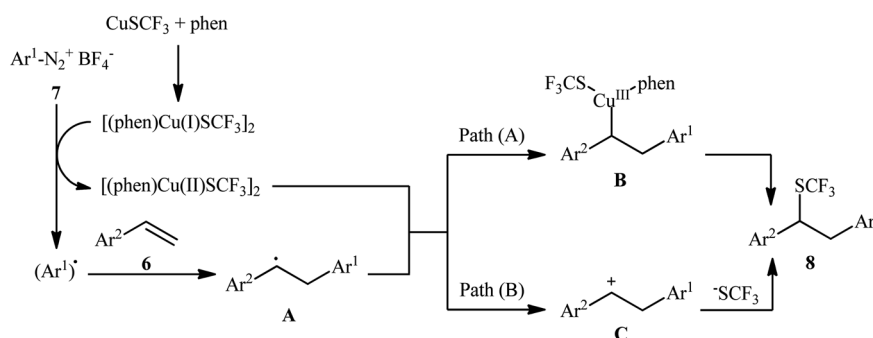

Scheme 6 Mechanism proposed to explain the formation of (1,2-diarylethyl)(trifluoromethyl)sulfanes **8**.



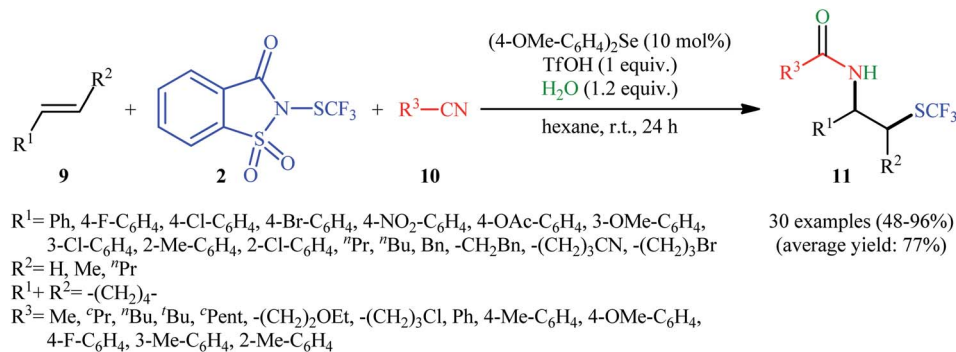

Scheme 7 Diaryl selenide-catalyzed vicinal amino-trifluoromethylthiolation of alkenes **9** by Shen's reagent **2** and nitriles **10** in the presence of water.

method was ineffective for *ortho*-substituted electron-poor arenediazonium salts. The plausible mechanism proposed by the authors to explain this transformation is illustrated in Scheme 6. Initially, reaction between CuSCF_3 and 1,10-phenanthroline (phen) leads to the formation of dimeric complex $[(\text{phen})\text{Cu}(\text{I})\text{SCF}_3]_2$, which after oxidation with arenediazonium salt **7** provides the corresponding copper(II) species and an aryl radical. Subsequent addition of the aryl radical to the styrene **6** results in the formation of benzylic radical **A**. Next, the reaction of the newly formed radical with $[(\text{phen})\text{Cu}(\text{II})\text{SCF}_3]_2$ affords $\text{Cu}(\text{III})$ complex **B**, which after reductive elimination provides the expected product **8** (Scheme 6, path a). In another possibility, oxidation of benzylic radical **A** by a $\text{Cu}(\text{II})$ cation leads to the formation of cationic intermediate **C**, which on subsequent

attack by a CF_3S ion yields the final desired product **3** (Scheme 6, path b).

3. Amino-trifluoromethylthiolation

In 2015, Zhao and co-workers reported one of the earliest vicinal trifluoromethylthiolative amination reactions to produce β - SCF_3 -substituted amides **11** from the readily available alkenes **9**, *N*- SCF_3 reagent **2**, and nitriles **10** in the presence of water (Scheme 7).¹⁶ This transformation was catalyzed by an electron-rich diaryl selenide [bis(4-methoxyphenyl)selane; (4-OMe- C_6H_4)₂Se] and a weak sulfonic acid. The reaction displayed a broad substrate scope, and various important functional groups such as fluoro, chloro, bromo, methoxy, acetoxy, and nitro were tolerated. It is worth noting that, by replacing nitriles

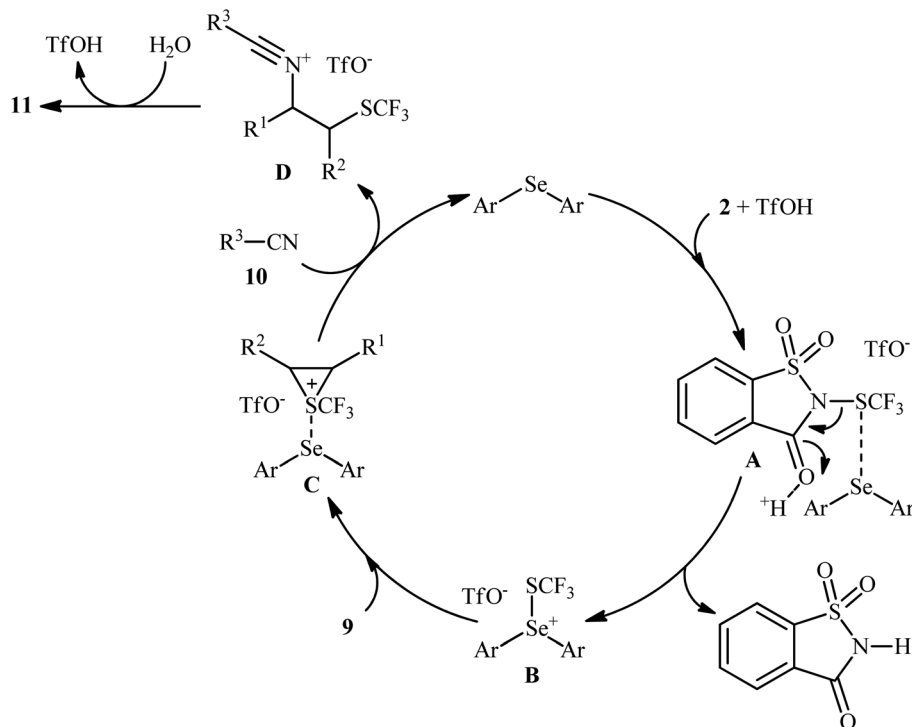

Scheme 8 Probable mechanism of trifluoromethylthioamination of alkenes **9** by *N*- SCF_3 reagent **2** and nitriles **10**.



with carboxylic acids, various aromatic and aliphatic alkenes could be trifluoromethylthioesterified in high yields. In this case, no additional reaction solvent was necessary, since the acids played a dual role as the solvent and the substrates. As shown in Scheme 8, a plausible reaction mechanism was suggested by the authors for this difunctionalization reaction. First, the reaction of diaryl selenide with reagent **2** in the presence of TfOH gives selenonium triflate intermediate **B** and saccharin through transition state **A**. Later, the highly reactive intermediate **B** interacts with alkene **9** to form the trifluoromethylthiiranium ion **C**. A subsequent nucleophilic attack of nitrile **10** on this intermediate **C** produces the nitrilium ion **D** through an *anti* addition involving the opening of the thiiranium intermediate. Finally, hydrolysis of intermediate **D** affords the expected product **11**.

In the same year, the Wang group disclosed a highly atom-economical direct trifluoromethylthioamination of α,β -unsaturated ketones and esters **12** using *N*-trifluoromethylthio-4-nitrophthalimide **13** as both the nitrogen and SCF₃ sources under metal-free and mild conditions (Scheme 9).¹⁷ The reaction was conducted in the presence of substoichiometric

amounts of DABCO at room temperature under open air, tolerated both aromatic and aliphatic ketones and esters **12**, and provided α -trifluoromethylthiolated β -amino carbonyl compounds **14** in moderate to excellent yields. However, acrylonitriles afforded lower yields and α,β -unsaturated amides failed to provide the desired products. It should be mentioned that the synthesized α -SCF₃- β -*N*-phthaloylamino acid esters could be easily converted to the corresponding β -amino acids *via* hydrogenation with Et₃SiH, followed by treatment with NaBH₄. Studies showed that when the newly developed reagent **13** was replaced by SCF₃-phthalimide, the reaction furnished the corresponding trifluoromethylthioaminated products, albeit with reduced yields. On the contrary, replacing compound **13** by either *N*-SCF₃-aniline or SCF₃-succinimide did not give the expected products. Therefore, the authors hypothesized that SCF₃-4-nitrophthalimide **13** functions as both the electrophilic SCF₃ and nitrogen sources, while SCF₃-aniline and SCF₃-succinimide are not electrophilic enough to react with alkenes under the identical conditions. The plausible mechanism of this trifluoromethylthioamination is represented in Scheme 10.

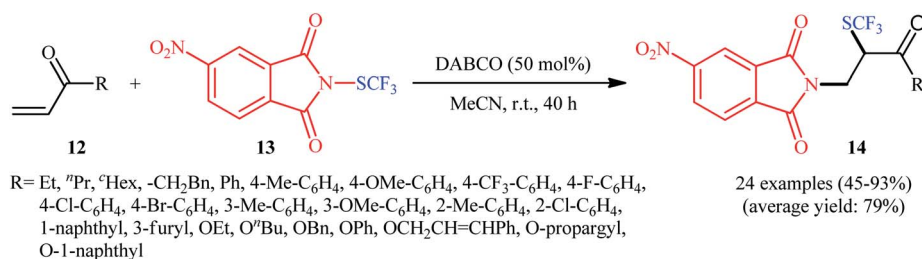

Scheme 9 DABCO-catalyzed amino-trifluoromethylthiolation of α,β -unsaturated carbonyl compounds **12** with *N*-trifluoromethylthio-4-nitrophthalimide **13**.

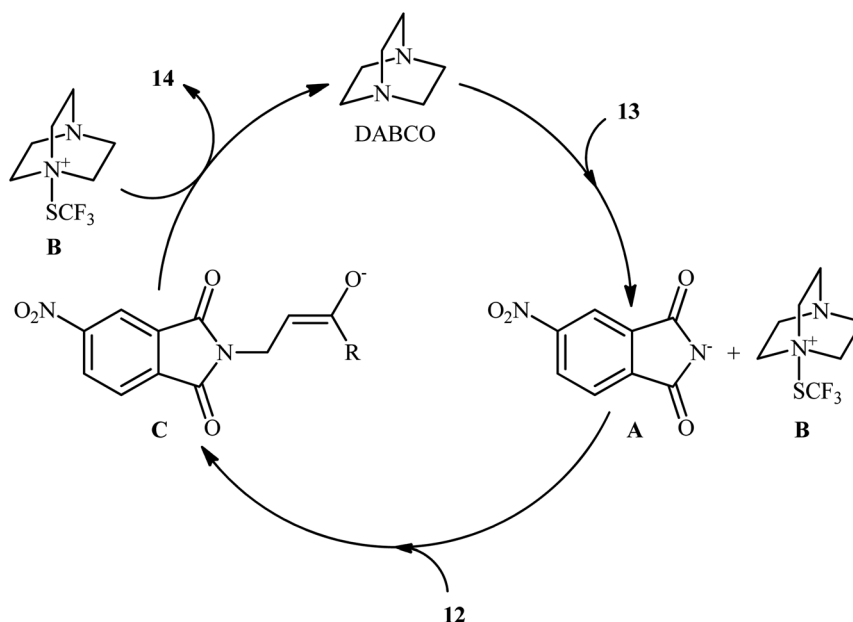

Scheme 10 Proposed mechanism for the reaction in Scheme 9.

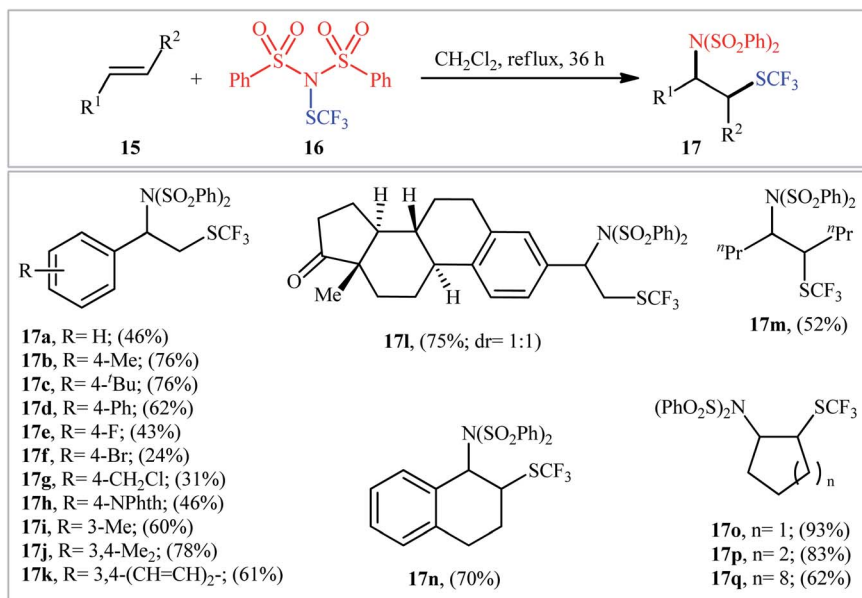

Scheme 11 Shen's synthesis of β -SCF₃-substituted amines 17.

By a similar strategy, Shen and colleagues reported a facile synthesis of β -SCF₃-substituted amines 17 from unactivated alkenes 15 and *N*-trifluoromethylthio-dibenzenesulfonamide 16 in DCM media under catalyst- and additive-free conditions (Scheme 11).¹⁸ In this study, 17 aromatic and aliphatic alkenes were amino-trifluoromethylthio difunctionalized with fair to very good yields. Noteworthy, both acyclic and cyclic alkenes were compatible with the reaction conditions. Interestingly, when the reaction was performed in more polar solvent DMF, the corresponding trifluoromethylthiolated alkenes were obtained as the sole products.

4. Oxy-trifluoromethylthiolation

The first mention of the direct oxytrifluoromethylthiolation of alkenes can be found in a 2009 paper by Billard *et al.*,¹⁹ who showed that the treatment of aliphatic alkenes 18 with trifluoromethanesulfanyl amide 19 and sodium tosylate as the ⁺SCF₃ and ⁻OTs sources, respectively, in the presence of 5 equiv. of BF₃·Et₂O as a mediator in DCM at room temperature afforded the corresponding β -(trifluoromethyl)alkyl tosylates 20 in moderate to high yields with complete regioselectivity (Scheme 12). Other Lewis acids, such as (Bu)₂BOTf and TfOSiMe₃, were

tested and showed lower efficiency than that of BF₃·Et₂O. Notably, Cu(OTf)₂, Yb(OTf)₃, La(OTf)₃, and In(OTf)₃, and Ti(O^{*i*}Pr)₄ proved to be completely ineffective. The same difunctionalization reaction was also investigated with alkynes. The reaction gave satisfactory yields, but the regioselectivity was not controlled in the case of disubstituted alkynes since an equal amount of the two regioisomers was obtained. It should be mentioned that the presence of the tosyl group provides the opportunity for further functionalization of the products using convenient S_N2 reactions, as exemplified by the synthesis of 2-trifluoromethylsulfanyl cyclohexyl amine from cyclohexene over 3 steps (*i.e.*, oxy-trifluoromethylthiolation, azidation, protonation).

Eight years later, Koike and Akita developed an efficient photoredox-catalyzed regioselective hydroxytrifluoromethylthiolation of alkenes under irradiation of visible light.²⁰ Using 5 mol% of *fac*-[Ir(4-MeO-ppy)₃] (4-MeO-ppy = 2-pyridyl-5-methoxyphenyl) as the catalyst, a library of terminal and internal aromatic alkenes 21 underwent regioselective hydroxytrifluoromethylthiolation with *N*-trifluoromethylthiosuccinimide 22 and water to afford the corresponding β -trifluoromethylthiolated benzyl alcohols 23 in fair to excellent yields (Scheme 13). Besides water, alcohols (*e.g.*, MeOH, EtOH and ^{*i*}PrOH) also could be utilized as the sources of oxy functional groups. However, the applicability of

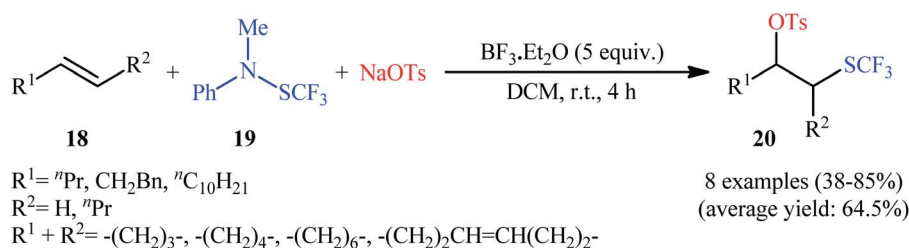

Scheme 12 Lewis acid-mediated oxytrifluoromethylthiolation of alkenes 18 developed by Billard.



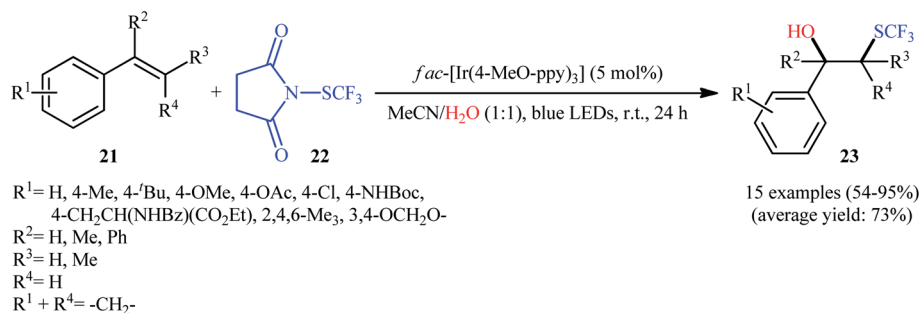

Scheme 13 Hydroxytrifluoromethylthiolation of alkenes **21** with *N*-trifluoromethylthiosuccinimide **22** by a visible light-activation system in aqueous acetonitrile.

aliphatic alkenes as starting materials was not investigated in this study. The mechanism of this reaction as proposed by the authors is shown in Scheme 14. Firstly, the ground state photocatalyst Ir^{III} undergoes photoexcitation under irradiation of visible light to produce the excited state $[\text{Ir}^{\text{III}}]^*$, which after a SET to the electrophilic CF_3S reagent **22** leads to the generation of the $\cdot\text{CF}_3$ radical and the highly oxidized Ir catalyst, Ir^{IV} . Thereafter, the $\cdot\text{CF}_3$ radical reacts with styrene **21** to form the benzyl radical intermediate **A**, which after oxidation by Ir^{IV} provides the carbocationic intermediate **B** and regenerates photocatalyst Ir^{III} . Finally, nucleophilic attack of water on the carbocation **B** produces the desired β - SCF_3 -substituted benzyl alcohol **23**. Another independent hydroxytrifluoromethylthiolation method was published by Luo and co-workers using *N*- CF_3S -saccharin reagent and $(4\text{-OMe-C}_6\text{H}_4)_2\text{Se}$ catalyst under conventional conditions.²¹ However, in this method, the reaction required an oxygen atmosphere. Various styrene derivatives and aliphatic alkenes were tolerated by this protocol. Moreover, similar conditions proved suitable for the intramolecular cyclization of alkenes tethered by carboxylic acid, hydroxy, ester, and sulfamide groups. Subsequently, the same authors extended their methodology to the enantioselective oxytrifluoromethylthiolation of internal alkenes using chiral selenide catalysis.^{22,23}

Very recently, the group of Li studied the possibility of synthesizing trifluoromethylthio peroxides through the direct Cu-catalyzed trifluoromethylthiolation–peroxidation of C–C double bonds.²⁴ In this study, a diverse array of β -

trifluoromethylthio peroxides **25** were obtained in 31–86% yields with excellent regioselectivities by reaction of various terminal and internal alkenes **24** with AgSCF_3 and *tert*-butyl hydroperoxide ($^t\text{BuOOH}$) in refluxing MeCN for 5 h in the presence of a $\text{CuSO}_4/\text{HMPA}/\text{K}_2\text{S}_2\text{O}_8$ combination as the catalytic system (Scheme 15). The results indicated that the best results were obtained in the case of aromatic and heteroaromatic alkenes. On the contrary, aliphatic alkenes were unfavorable for the reaction and led to lower yields. It is worthwhile to note that the identical condition was also successfully applied for trifluoromethylthiolation–peroxidation of a library of mono- and 1,1-disubstituted allenes. The authors nicely demonstrated the synthetic value of β -trifluoromethylthio peroxide products by the conversion of a peroxide group to hydroxyl and carbonyl moieties. The radical trapping experiments pointed toward a radical reaction mechanism.

5. Thio-trifluoromethylthiolation

In 2017, Xu *et al.* for the first time reported the regioselective trifluoromethylthiosulfonylation of alkenes under the action of dual gold and photoredox catalysis.²⁵ They demonstrated that *S*-(trifluoromethyl)benzenesulfonylthioate ($\text{PhSO}_2\text{SCF}_3$; **27**) acted as both the trifluoromethylthiolating and sulfonylating agents in the presence of $\text{Ru}(\text{bpy})_3\text{Cl}_2$ as a photocatalyst and IPrAuCl as a cationic gold catalyst under the irradiation of a 100 W blue

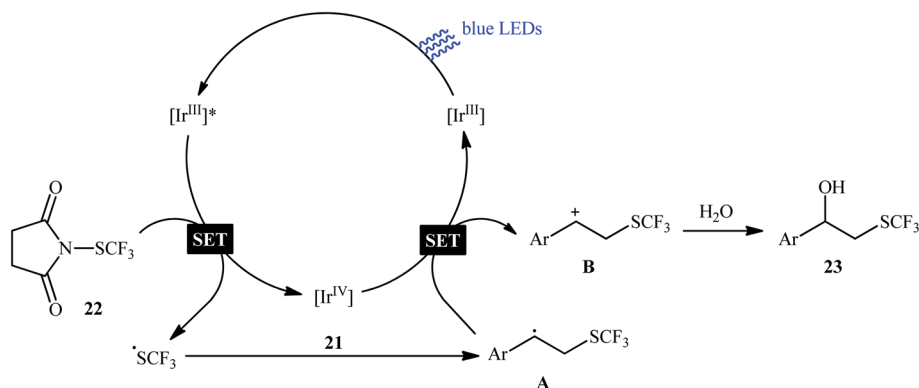

Scheme 14 Proposed mechanism for the visible light-induced hydroxytrifluoromethylthiolation of alkenes **21** with *N*-trifluoromethylthiosuccinimide **22** and water.

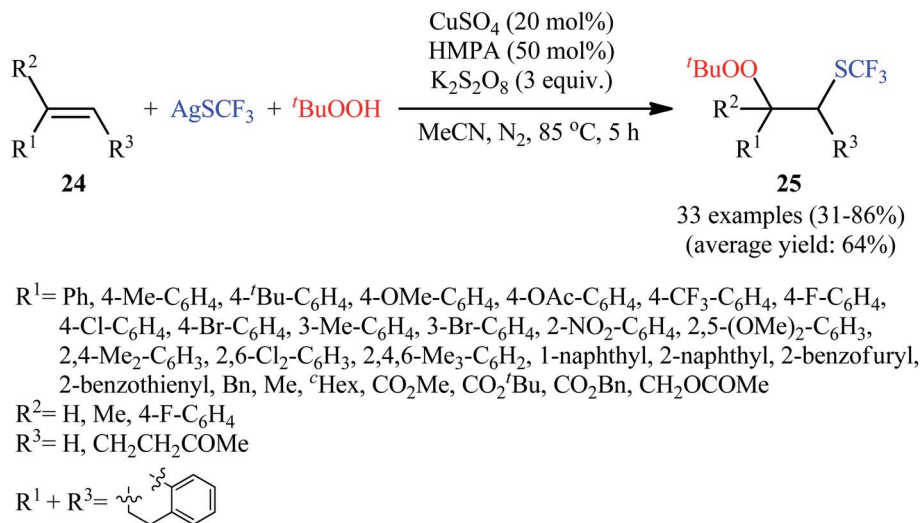

Scheme 15 Cu-catalyzed trifluoromethylthiolation-oxidation of alkenes **24** with AgSCF_3 and ${}^t\text{BuOOH}$.

LED in an inert atmosphere. Additionally, 15 mol% of AgSbF_6 was needed as an additive for this transformation. Under the optimized reaction conditions, various styrene derivatives **26** with different substitution patterns and functionalities rapidly underwent this difunctionalization reaction and afforded the corresponding β - SCF_3 -substituted sulfones **28** in moderate to excellent yields (Scheme 16). The methodology was also applicable for the other related *S*-alkyl/aryl benzenesulfonothioates like PhSO_2SMe , PhSO_2SBn , $\text{PhSO}_2\text{SC}_4\text{H}_9$ and PhSO_2SPh . It is worthwhile to note that when the internal alkenes were employed as reaction substrates, very good diastereoselectivities were observed and both *trans*- and *cis*-alkenes yielded the same diastereomer. Moreover, the authors displayed the synthetic applicability of the prepared β - SCF_3 -substituted sulfones by high yielding preparation of β -cyano and β -allyl thioethers *via* the reaction with TMSCN and allylsilane, respectively, in the presence of aluminium chloride. Mechanistically, these reactions are believed to proceed through the sulfur migration substitution pathway.

Concurrently, Qing's research group disclosed an excellent strategy for oxidative bis(trifluoromethylthiolation) of 2-mono-substituted 2,3-allenoic acids **29** employing AgSCF_3 as the source of the trifluoromethylthiol group in the presence of a catalytic amount of inexpensive $\text{Cu}(\text{OAc})_2$ combined with

$(\text{NH}_4)_2\text{S}_2\text{O}_8$ as a stoichiometric oxidant.²⁶ It was found that the solvent had a major impact on the success of this reaction and the highest yield was obtained in $\text{MeCN}/\text{HCO}_2\text{H}/\text{H}_2\text{O}$ (4 : 1 : 2). Under the optimized conditions, the reaction exhibited excellent regioselectivity and provided 3,4-bis(trifluoromethylthio) but-2-enoic acid products **30** in moderate to good yields (Scheme 17). In contrast, when 4-aryl-2,3-allenoic acids were employed under the identical conditions, a different outcome was obtained. In these cases, 4-((trifluoromethylthio)furan-2(5*H*)-ones were selectively generated in modest to excellent yields through radical trifluoromethylthiolation/intramolecular cyclization. While the detailed mechanistic picture for the formation of 3,4-bis(trifluoromethylthio) but-2-enoic acid products **30** remains unclear, the authors postulated that the reaction may start with the formation of a CF_3S radical or CF_3SSCF_3 *via* oxidation of AgSCF_3 by $(\text{NH}_4)_2\text{S}_2\text{O}_8$ through a $\text{Ag}^{\text{II}}\text{SCF}_3$ intermediate. Next, the SCF_3 radical adds to the central carbon of allene **29** leading to allylic radical species **A** and **A'**. The thermodynamically more favored **A** is then trapped by a Cu salt to give the SCF_3 -allyl-Cu complex **B**. Finally, the trifluoromethylthiolation of this complex **B** with CF_3SSCF_3 affords the expected bis-trifluoromethylthiolated products **30** (Scheme 18).

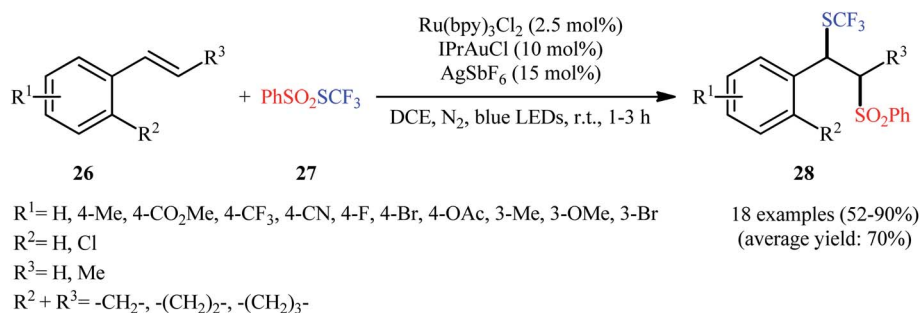
Scheme 16 Dual gold and visible light-mediated trifluoromethylthiosulfonation of alkenes **26** with $\text{PhSO}_2\text{SCF}_3$.

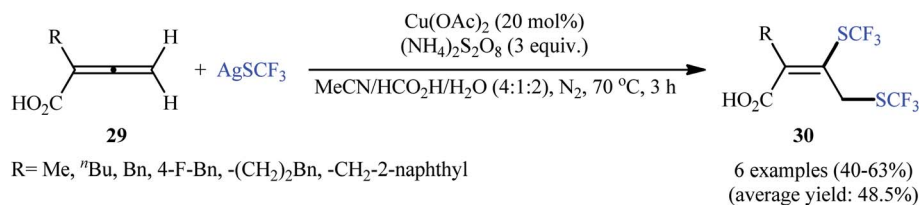
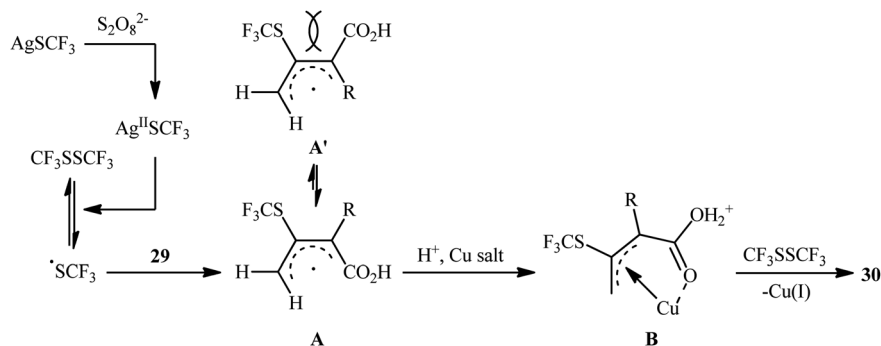
Scheme 17 Cu-catalyzed bis(trifluoromethylthiolation) of allenes **29** with AgSCF₃.Scheme 18 Plausible mechanism for the oxidative bis(trifluoromethylthiolation) of 2-mono-substituted 2,3-allenoic acids **29**.

Very recently, Zhang and Ma, along with their co-workers, reported a three-component thio-trifluoromethylthiolation of aliphatic terminal alkenes **31** with aryldisulfides **32** and electrophilic trifluoromethylthiolating reagent **33** through visible light photoredox catalysis.²⁷ This reaction employed 1,2,3,5-tetrakis(carbazol-9-yl)-4,6-dicyanobenzene (4CzIPN) as an organic photocatalyst, K₂HPO₄ as an additive, and blue LEDs as

the light source, leading to the production of aryl(2-((trifluoromethylthio)ethyl)sulfane derivatives **34** in moderate to good yields, ranging from 48–78% (Scheme 19). Notably, this methodology was applicable to the difunctionalization of boldenone- and D-glucose-derived terminal alkenes, indicating a potential application in the design and synthesis of biologically active molecules. Unfortunately, the applicability of

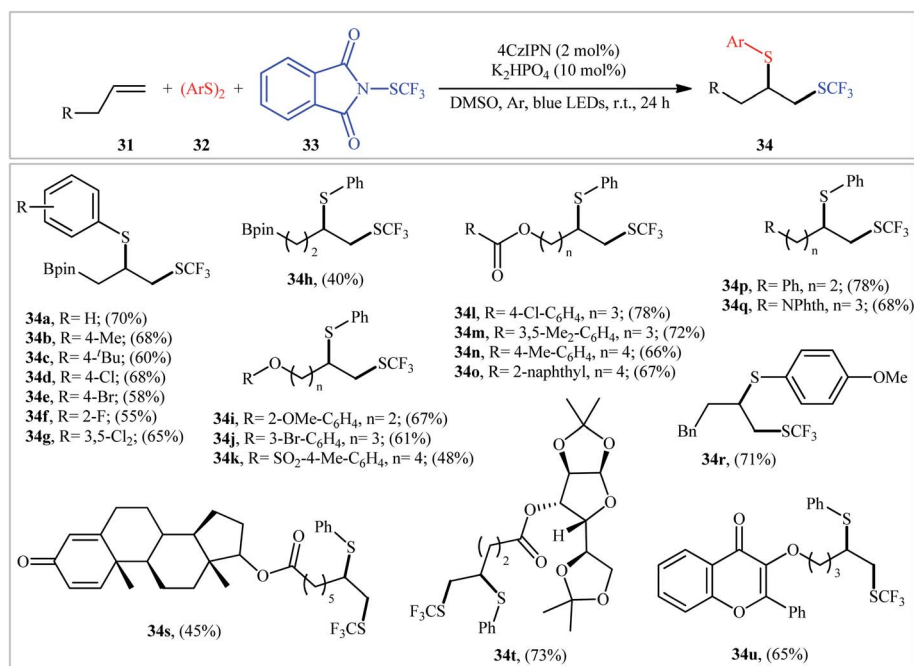
Scheme 19 Visible light-induced thio-trifluoromethylthiolation of unactivated terminal alkenes **31** with aryldisulfides **32** and Phth-SCF₃ reagent **33**.

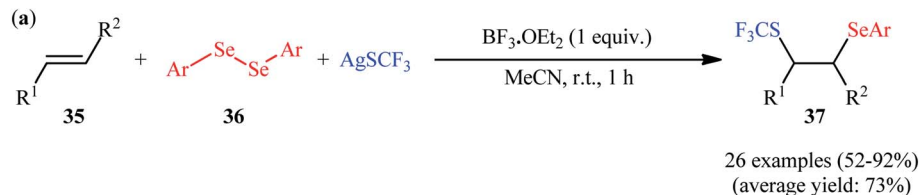

$R^1 = \text{Bn, Ph, 4-Me-C}_6\text{H}_4, 4\text{'-Bu-C}_6\text{H}_4, 4\text{-Br-C}_6\text{H}_4, 3\text{-Cl-C}_6\text{H}_4, 3\text{-Br-C}_6\text{H}_4, 2\text{-Me-C}_6\text{H}_4, 3,4\text{-(OMe)}_2\text{-C}_6\text{H}_3, 2\text{-naphthyl, }-(\text{CH}_2)_2\text{OTs, }-(\text{CH}_2)_2\text{O(4-I-C}_6\text{H}_4), -(\text{CH}_2)_2\text{O(4-CHO-C}_6\text{H}_4), -(\text{CH}_2)_2\text{O-1-naphthyl}$
 $R^2 = \text{H}$
 $R^1 + R^2 = -(\text{CH}_2)_3-, -(\text{CH}_2)_4-, -(\text{CH}_2)_5-,$ 
 $\text{Ar} = \text{Ph, 4-Me-C}_6\text{H}_4, 4\text{-OMe-C}_6\text{H}_4, 4\text{-F-C}_6\text{H}_4, 4\text{-Cl-C}_6\text{H}_4, 3\text{-OMe-C}_6\text{H}_4, 2\text{-OMe-C}_6\text{H}_4, 3,4\text{-OCH}_2\text{O-C}_6\text{H}_3$

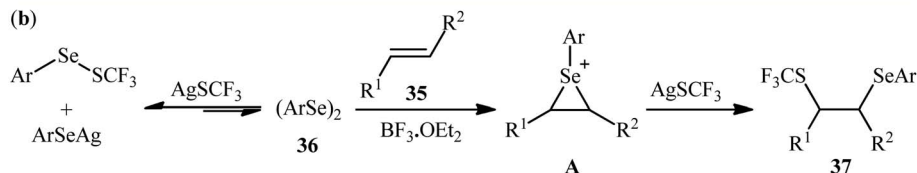

Scheme 20 (a) Metal-free selenotrifluoromethylthiolation of alkenes **35** with diaryl diselenides **36** and AgSCF_3 . (b) Proposed mechanism for the formation of 1,2-dichalcogenated products **37**.

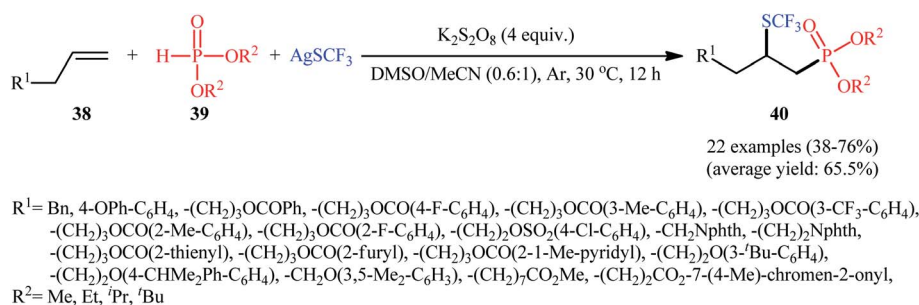

Scheme 21 Phosphonotrifluoromethylthiolation of aliphatic alkenes **38** with dialkyl phosphonates **39** and AgSCF_3 .

alkyldisulfides as starting materials was not investigated in this study. Mechanistic elucidation through radical trapping experiments in the presence of 2,2,6,6-tetramethylpiperidin-1-oxyl (TEMPO) indicated a radical pathway for the transformation.

6. Seleno-trifluoromethylthiolation

In 2019, Anbarasan and Saravanan devised an efficient method for the direct selenotrifluoromethylthiolation of alkenes **35** with

diaryl diselenides **36** and AgSCF_3 at room temperature by means of $\text{BF}_3 \cdot \text{OEt}_2$ as an activator.²⁸ 18 alkenes (aromatic and aliphatic) and 8 diaryl diselenides (electron-rich and electron-poor) were used as substrates in this study and 26 1,2-dichalcogenated products **37** were synthesized in moderate to excellent yields within 1 h (Scheme 20a). Interestingly, the prepared difunctionalized products could be easily converted to the corresponding vinyl trifluoromethyl thioethers when treated with *m*-CPBA in DCM at room temperature. The mechanistic

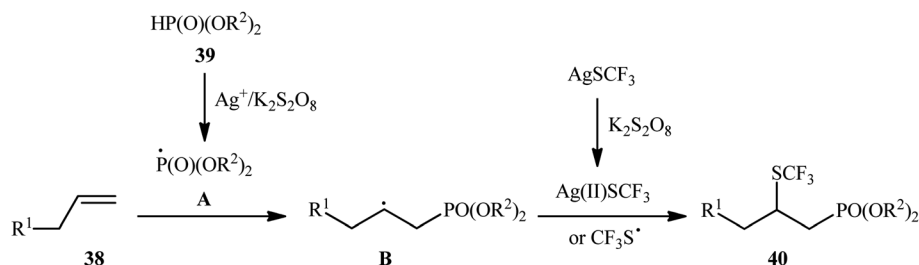

Scheme 22 Plausible mechanism for the reaction in Scheme 21.

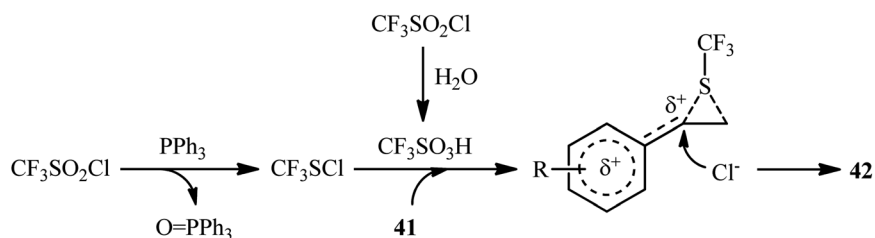

Scheme 23 Metal-free chlorotrifluoromethylthiolation of styrenes **41** with CF₃SO₂Cl.

Scheme 24 Proposed mechanistic pathways for the reaction in Scheme 23.

pathway proposed by the authors to explain this difunctionalization reaction is based on the formation of an episelenonium intermediate, followed by its regioselective ring opening with AgSCF₃ (Scheme 20b).

7. Phosphono-trifluoromethylthiolation

In 2018, Liu and co-workers illustrated an interesting regioselective oxidative phosphonotrifluoromethylthiolation of unactivated alkenes with P(O)-H compounds and AgSCF₃ in which 4 equiv. of inexpensive K₂S₂O₈ were employed as an oxidant.²⁹ A variety of aliphatic alkenes **38** and dialkyl phosphonates **39** were well tolerated in the reaction process and gave the β-trifluoromethylthiol phosphonates **40** in 38–76% yields (Scheme 21). However, both aromatic alkenes and diaryl phosphonates were incompatible in the reaction and the applicability of other hydrogen phosphoryl compounds (H-phosphinates and secondary phosphine oxides) as substrates was not investigated in this study. On the basis of experimental observations, the authors suggested a plausible mechanism for this reaction as depicted in Scheme 22. First, the oxidation of the phosphonate **39** with Ag⁺/K₂S₂O₈ into its corresponding phosphonyl radical **A** takes place. Thus, its addition with alkene **38** gives the alkyl radical **B**, which undergoes coupling with a CF₃S radical or Ag(II) SCF₃ (produced by the oxidation of AgSCF₃ with K₂S₂O₈) releasing the required product **40**.

8. Chloro-trifluoromethylthiolation

In 2018, Yi-Zhang's group studied the direct chlorotrifluoromethylthiolation of unactivated C=C double bonds with triflyl chloride (CF₃SO₂Cl) as both the chlorine and SCF₃ sources under metal-free conditions.³⁰ Thus, in the presence of over-

stoichiometric amounts of PPh₃ as a low-cost reductant in DMF under an air atmosphere, chlorotrifluoromethylthiolation of various styrenes **41** having both electron-withdrawing and electron-releasing groups with CF₃SO₂Cl furnished the corresponding (2-chloro-2-arylethyl)(trifluoromethyl)sulfanes **42** in moderate to high yields and excellent Markovnikov-selectivity (Scheme 23). The reaction was also amenable to the chlorotrifluoromethylthiolation of terminal aliphatic alkenes, while anti-Markovnikov adducts were the major regioisomers. However, internal alkenes did not respond to the reaction under standard conditions. Interestingly, this chlorotrifluoromethylthiolation chemistry was also successfully extended to terminal alkynes. Similar to trifluoromethylthiolation, the method could be used for difluoromethylthiolation using CF₂HOSO₂Cl as a reagent. The plausible mechanism of this difunctionalization reaction is represented in Scheme 24.

Concurrently, Yang and co-workers reported that various terminal and internal alkenes could regio-selectively undergo chlorotrifluoromethylthiolation with Phth-SCF₃ and SOCl₂ mediated by Fe₂O₃, furnishing the corresponding trifluoromethylthiolated chlorides in moderate to almost quantitative yields.³¹ It is worth noting that quaternary carbon centers could be readily built up using internal alkene substrates with a >20 : 1 diastereomeric ratio under the reaction conditions.

Finally, it should be noted that transition metal complexes play important roles in intermolecular 1,2-difunctionalization of alkenes and the synthesis of organic compounds.^{32–40}

9. Conclusion

The direct vicinal difunctionalization of unsaturated hydrocarbons represents one of the most powerful and fascinating tactics for increasing molecular complexity by forging two chemical bonds across an unsaturated carbon-carbon bond in



a single reaction. In this family of reactions, intermolecular trifluoromethylthiolative 1,2-difunctionalization of alkenes has attracted a lot of attention from researchers in recent years due to the potential biological activities of the resulting β -functionalized alkyl trifluoromethyl sulfides. As shown in this review, over the last few years, a handful of attractive carbo- and hetero-trifluoromethylthiolation reactions of alkenes were developed that allow for efficient, clean, and selective synthesis of various β -functionalized alkyl trifluoromethyl sulfides. Noteworthy, the majority of these reactions were performed at room temperature and under transition-metal-free conditions. Challenges that remain to be faced in the future include: (i) development of chiral catalytic systems for enantioselective difunctionalization of trifluoromethylthiolations; (ii) extension of hetero-trifluoromethylthiolation reactions to other hetero-atoms such as silica- and bora-trifluoromethylthiolations; and (iii) further investigation of the scope and limitations of some reactions, such as phosphono- and seleno-trifluoromethylthiolations.

Conflicts of interest

There are no conflicts to declare.

References

- (a) E. P. Gillis, K. J. Eastman, M. D. Hill, D. J. Donnelly and N. A. Meanwell, *J. Med. Chem.*, 2015, **58**, 8315–8359; (b) M. Inoue, Y. Sumii and N. Shibata, *ACS Omega*, 2020, **5**, 10633–10640.
- (a) M. M. Alauddin, *Am. J. Nucl. Med. Mol. Imaging*, 2012, **2**, 55–76; (b) F. John, O. Muzik, S. Mittal and C. Juhász, *Mol. Imaging Biol.*, 2020, **22**, 805–819.
- Y. Zhou, J. Wang, Z. Gu, S. Wang, W. Zhu, J. L. Aceña, V. A. Soloshonok, K. Izawa and H. Liu, *Chem. Rev.*, 2016, **116**, 422–518.
- V. V. Grushin, *Acc. Chem. Res.*, 2010, **43**, 160–171.
- X.-H. Xu, K. Matsuzaki and N. Shibata, *Chem. Rev.*, 2015, **115**, 731–764.
- (a) F. Toulgoat, S. Alazet and T. Billard, *Eur. J. Org. Chem.*, 2014, 2415–2428; (b) J.-H. Lin, Y.-L. Ji and J.-C. Xiao, *Curr. Org. Chem.*, 2015, **19**, 1541–1553; (c) H. Chachignon and D. Cahard, *Chin. J. Chem.*, 2016, **34**, 445–454; (d) H. Zheng, Y. Huang and Z. Weng, *Tetrahedron Lett.*, 2016, **57**, 1397–1409; (e) A.-L. Barthelemy, E. Magnier and G. Dagousset, *Synthesis*, 2018, **50**, 4765–4776; (f) M. Hamzehloo, A. Hosseini, S. Ebrahimi, A. Monfared and E. Vessally, *J. Fluorine Chem.*, 2019, **224**, 52–60.
- (a) J. Lin, R. J. Song, M. Hu and J. H. Li, Recent advances in the intermolecular oxidative difunctionalization of alkenes, *Chem. Rec.*, 2019, **19**, 440–451; (b) J. B. Peng, *Adv. Synth. Catal.*, 2020, **362**, 3059–3080; (c) Y. C. Wu, Y. T. Xiao, Y. Z. Yang, R. J. Song and J. H. Li, *ChemCatChem*, 2020, **12**, 5312–5329; (d) A. Whyte, A. Torelli, B. Mirabi, A. Zhang and M. Lautens, *ACS Catal.*, 2020, **10**, 11578–11622; (e) H.-Y. Tu, S. Zhu, F.-L. Qing and L. Chu, *Synthesis*, 2020, **52**, 1346–1356; (f) Z.-L. Li, G.-C. Fang, Q.-S. Gu and X.-Y. Liu, *Chem. Soc. Rev.*, 2020, **49**, 32–48; (g) S. Yang, Y. Chen and Z. Ding, *Org. Biomol. Chem.*, 2020, **18**, 6983–7001; (h) N. Yue and F. R. Sheykahmad, *J. Fluorine Chem.*, 2020, 109629.
- A. Bakhtiary, M. R. P. Heravi, A. Hassanpour, I. Amini and E. Vessally, *RSC Adv.*, 2021, **11**, 470–483.
- (a) A. Monfared, S. Ebrahimi, M. Babazadeh, S. Arshadi and E. Vessally, *J. Fluorine Chem.*, 2019, **220**, 24–34; (b) A. Hosseini, Y. J. Sadeghi, S. Ebrahimi, A. Monfared and E. Vessally, *J. Sulfur Chem.*, 2019, **40**, 565–585; (c) C. Yang, A. Hassanpour, K. Ghorbanpour, S. Abdolmohammadi and E. Vessally, *RSC Adv.*, 2019, **9**, 27625–27639; (d) N. H. Jabarullah, K. Jermsittiparsert, P. A. Melnikov, A. Maselena, A. Hosseini and E. Vessally, *J. Sulfur Chem.*, 2020, **41**, 96–115.
- (a) E. Vessally, K. Didehban, R. Mohammadi, A. Hosseini and M. Babazadeh, *J. Sulfur Chem.*, 2018, **39**, 332–349; (b) E. Vessally, R. Mohammadi, A. Hosseini, K. Didehban and L. Edjlali, *J. Sulfur Chem.*, 2018, **39**, 443–463; (c) F. A. H. Nasab, L. Z. Fekri, A. Monfared, A. Hosseini and E. Vessally, *RSC Adv.*, 2018, **8**, 18456–18469; (d) A. Hosseini, L. Zare Fekri, A. Monfared, E. Vessally and M. Nikpassand, *J. Sulfur Chem.*, 2018, **39**, 674–698; (e) A. Hosseini, S. Ahmadi, F. A. H. Nasab, R. Mohammadi and E. Vessally, *Top. Curr. Chem.*, 2018, **376**, 1–32; (f) A. Hosseini, S. Arshadi, S. Sarhandi, A. Monfared and E. Vessally, *J. Sulfur Chem.*, 2019, **40**, 289–311; (g) N. H. Jabarullah, K. Jermsittiparsert, P. A. Melnikov, A. Maselena, A. Hosseini and E. Vessally, *J. Sulfur Chem.*, 2020, **41**, 96–115; (h) X. Lu, Q. Yi, X. Pan, P. Wang and E. Vessally, *J. Sulfur Chem.*, 2020, **41**, 210–228; (i) S. Sarhandi, M. Daghadheleh, M. Vali, R. Moghadami and E. Vessally, *Chem. Rev. Lett.*, 2018, **1**, 9–15; (j) M. R. J. Sarvestani, N. Mert, P. Charehjou and E. Vessally, *J. Chem. Lett.*, 2020, **1**, 93–102; (k) M. Daghadheleh, M. Vali, Z. Rahmani, S. Sarhandi and E. Vessally, *Chem. Rev. Lett.*, 2018, **1**, 23–30; (l) L. Sreerama, E. Vessally and F. Behmagham, *J. Chem. Lett.*, 2020, **1**, 9–18; (m) S. Shahidi, P. Farajzadeh, P. Ojaghloo, A. Karbakhshzadeh and A. Hosseini, *Chem. Rev. Lett.*, 2018, **1**, 37–44.
- J. Fang, Z. K. Wang, S. W. Wu, W. G. Shen, G. Z. Ao and F. Liu, *Chem. Commun.*, 2017, **53**, 7638–7641.
- S. Liang, J. Wei, L. Jiang, J. Liu, Y. Mumtaz and W. Li, *CCS Chem.*, 2021, **3**, 265–273.
- B. S. Zhang, L. Y. Gao, Z. Zhang, Y. H. Wen and Y. M. Liang, *Chem. Commun.*, 2018, **54**, 1185–1188.
- J. He, C. Chen, G. C. Fu and J. C. Peters, *ACS Catal.*, 2018, **8**, 11741–11748.
- Z. Xiao, Y. Liu, L. Zheng, C. Liu, Y. Guo and Q. Y. Chen, *J. Org. Chem.*, 2018, **83**, 5836–5843.
- J. Luo, Z. Zhu, Y. Liu and X. Zhao, *Org. Lett.*, 2015, **17**, 3620–3623.
- Q. Xiao, Q. He, J. Li and J. Wang, *Org. Lett.*, 2015, **17**, 6090–6093.
- P. Zhang, M. Li, X. S. Xue, C. Xu, Q. Zhao, Y. Liu, H. Wang, Y. Guo, L. Lu and Q. Shen, *J. Org. Chem.*, 2016, **81**, 7486–7509.



- 19 A. Ferry, T. Billard, B. R. Langlois and E. Bacqué, *Angew. Chem., Int. Ed.*, 2009, **121**, 8703–8707.
- 20 Y. Li, T. Koike and M. Akita, *Asian J. Org. Chem.*, 2017, **6**, 445–448.
- 21 Z. Zhu, J. Luo and X. Zhao, *Org. Lett.*, 2017, **19**, 4940–4943.
- 22 X. Liu, Y. Liang, J. Ji, J. Luo and X. Zhao, *J. Am. Chem. Soc.*, 2018, **140**, 4782–4786.
- 23 J. Xu, Y. Zhang, T. Qin and X. Zhao, *Org. Lett.*, 2018, **20**, 6384–6388.
- 24 Y. Chen, Y. Ma, L. Li, M. Cui and Z. Li, *Org. Chem. Front.*, 2020, **7**, 1837–1844.
- 25 H. Li, C. Shan, C. H. Tung and Z. Xu, *Chem. Sci.*, 2017, **8**, 2610–2615.
- 26 S. Pan, Y. Huang, X. H. Xu and F. L. Qing, *Org. Lett.*, 2017, **19**, 4624–4627.
- 27 X. Li, Q. Zhang, W. Zhang, J. Ma, Y. Wang and Y. Pan, *Beilstein J. Org. Chem.*, 2021, **17**, 551–557.
- 28 P. Saravanan and P. Anbarasan, *Chem. Commun.*, 2019, **55**, 4639–4642.
- 29 Z. Xiao, Y. Liu, L. Zheng, X. Zhou, Y. Xie, C. Liu, Y. Guo and Q. Y. Chen, *Tetrahedron*, 2018, **74**, 6213–6219.
- 30 L. Jiang, T. Ding, W. B. Yi, X. Zeng and W. Zhang, *Org. Lett.*, 2018, **20**, 2236–2240.
- 31 Y. Jia, H. Qin, N. Wang, Z. X. Jiang and Z. Yang, *J. Org. Chem.*, 2018, **83**, 2808–2817.
- 32 H. Zhang, *et al.*, The Role of Superoxide Radicals, *ACS Omega*, 2020, **5**, 18007–18012.
- 33 X. Pan, J. Wei, M. Zou, J. Chen, R. Qu and Z. Wang, *Water Res.*, 2021, **194**, 116916.
- 34 M. Zou, *et al.*, *Sci. Total Environ.*, 2021, **771**, 144743.
- 35 W. Cao, *et al.*, *Environ. Sci. Pollut. Res.*, 2021, **28**, 31301–31311.
- 36 Z. Liu, A. Ebadi, M. Toughani, N. Mert and E. Vessally, *RSC Adv.*, 2020, **10**, 37299–37313.
- 37 S. Ahmadi, A. Hosseinian, P. D. Kheirollahi Nezhad, A. Monfared and E. Vessally, *Iran. J. Chem. Chem. Eng.*, 2019, **38**, 1–19.
- 38 E. Vessally, S. Mohammadi, M. Abdoli, A. Hosseinian and P. Ojaghloo, *Iran. J. Chem. Chem. Eng.*, 2020, **39**, 11–19.
- 39 W. Xu, D. Guo, A. G. Ebadi, M. Toughani and E. Vessally, Transition-metal catalyzed carboxylation of organoboron compounds with CO₂, *J. CO₂ Util.*, 2021, **45**, 101403.
- 40 A. Hassanpour, M. R. P. Heravi, A. Ebadi, A. Hosseinian and E. Vessally, *J. Fluorine Chem.*, 2021, **245**, 109762.

