

RSC Sustainability

rsc.li/rscsus

The Royal Society of Chemistry is the world's leading chemistry community. Through our high impact journals and publications we connect the world with the chemical sciences and invest the profits back into the chemistry community.

IN THIS ISSUE

ISSN 2753-8125 CODEN RSSUAN 1(3) 391–650 (2023)

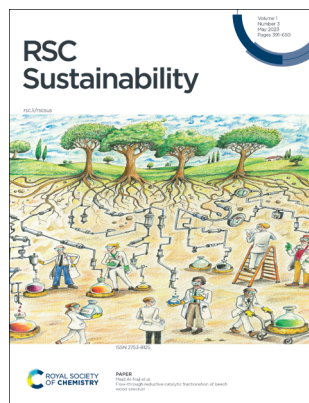

Cover
See Majd Al-Naji *et al.*, pp. 459–469. Image reproduced by permission of Majd Al-Naji from RSC. *Sustainability.*, 2023, 1, 459.



Inside cover
See Ryohei Kakuchi *et al.*, pp. 439–445. Image reproduced by permission of Ryohei Kakuchi from RSC. *Sustainability.*, 2023, 1, 439.

EDITORIAL

401

UN Sustainable Development Goals 14 and 15 – Life below water, Life on land

Francesca M. Kerton



CRITICAL REVIEWS

404

A critical review of the production of hydroxyaromatic carboxylic acids as a sustainable method for chemical utilisation and fixation of CO₂

Omar Mohammad, Jude A. Onwudili* and Qingchun Yuan

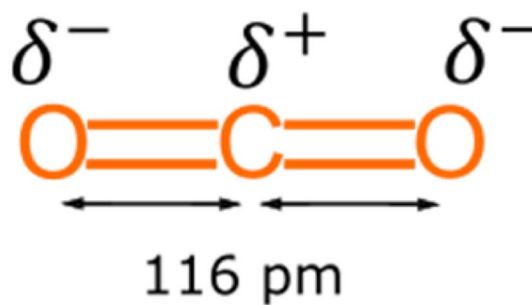

Editorial Staff**Executive Editor**

Emma Eley

Deputy Editor

Jon Ferrier

Editorial Production Manager

Sarah Whitbread

Assistant Editors

Jamie Purcell, Aphra Murray, Alexander John, Emily Ellison, Jack Pitchers

Editorial Assistant

Alex Holiday

Publishing Assistant

Lee Colwill

Publisher

Neil Hammond

For queries about submitted papers, please contact Sarah Whitbread, Editorial Production Manager in the first instance. E-mail: rscsus@rsc.org

For pre-submission queries please contact

Emma Eley, Executive Editor.

E-mail: rscsus-rsc@rsc.org

RSC Sustainability (electronic: ISSN 2753-8125) is published 6 times a year by the Royal Society of Chemistry, Thomas Graham House, Science Park, Milton Road, Cambridge, UK CB4 0WF.

RSC Sustainability is a Gold Open Access journal and all articles are free to read. Please email orders@rsc.org to register your interest or contact Royal Society of Chemistry Order Department, Royal Society of Chemistry, Thomas Graham House, Science Park, Milton Road, Cambridge, CB4 0WF, UK
Tel +44 (0)1223 432398;
E-mail: orders@rsc.org

Whilst this material has been produced with all due care, the Royal Society of Chemistry cannot be held responsible or liable for its accuracy and completeness, nor for any consequences arising from any errors or the use of the information contained in this publication. The publication of advertisements does not constitute any endorsement by the Royal Society of Chemistry or Authors of any products advertised. The views and opinions advanced by contributors do not necessarily reflect those of the Royal Society of Chemistry which shall not be liable for any resulting loss or damage arising as a result of reliance upon this material. The Royal Society of Chemistry is a charity, registered in England and Wales, Number 207890, and a company incorporated in England by Royal Charter (Registered No. RC000524), registered office: Burlington House, Piccadilly, London W1J 0BA, UK, Telephone: +44 (0) 207 4378 6556.

Advertisement sales:

Tel +44 (0) 1223 432246; Fax +44 (0) 1223 426017;

E-mail advertising@rsc.org

For marketing opportunities relating to this journal, contact marketing@rsc.org

RSC Sustainability

rsc.li/RSCSus

RSC Sustainability publishes experimental and theoretical work across the breadth of materials science.

Editorial Board**Editor-in-Chief**

Tom Welton, Imperial College London, UK

Associate Editors

Francesca Kerton, Memorial University of Newfoundland, Canada

Haichao Liu, Peking University, China

Vincent Nyamori, University of KwaZulu-Natal, Technology, China

South Africa

Cristina Pozo-Gonzalo, Deakin University,

Australia

Martin Prechtl, University of Lisbon, Portugal

Zhenyu Sun, Beijing University of Chemical

Editorial Board Members

David Cole-Hamilton, University of St

Andrews, UK

Mike Sutton, The Lubrizol Corporation, USA

Advisory Board

Jothi Kothandaraman, Pacific Northwest National Laboratory, USA

Chen Liao, Argonne National Laboratory, USA

Shengzhong Liu, Dalian National Laboratory for Clean Energy, China

Greta Patzke, University of Zurich, Switzerland

Peter Styring, The University of Sheffield, UK

Gyorgy Szekely, King Abdullah University of Science and Technology, Saudia Arabia

Luigi Vaccaro, University of Perugia, Italy

Sónia Ventura, University of Aveiro, Portugal

Charlotte Williams, University of Oxford, UK

Iris Yu, National University of Singapore, Singapore

Information for Authors

Full details on how to submit material for publication in RSC Sustainability are given in the Instructions for Authors (available from <http://www.rsc.org/authors>). Submissions should be made via the journal's homepage: rsc.li/RSCSus

Authors may reproduce/republish portions of their published contribution without seeking permission from the Royal Society of Chemistry, provided that any such republication is accompanied by an acknowledgement in the form: (Original Citation)–Reproduced by permission of the Royal Society of Chemistry.

This journal is © The Royal Society of Chemistry 2023. Apart from fair dealing for the purposes of research or private study for non-commercial purposes, or criticism or review, as permitted under the Copyright, Designs and Patents Act 1988 and the Copyright and Related Rights Regulation 2003, this publication may only be reproduced, stored or transmitted, in any form or by any means, with the prior permission in writing of the Publishers or in the case of reprographic reproduction in accordance with the terms of licences issued by the Copyright Licensing Agency in the UK. US copyright law is applicable to users in the USA.

Registered charity number: 207890



CRITICAL REVIEWS

418

Devising a people-friendly test kit for overcoming challenges in the assessment of water quality and analysis of water pollution in the river Ganga

Shraddha Chauhan, Anjali Yadav, Premnadh M. Kurup,*
Xia Li,* Pradip Swarnakar* and Raju Kumar Gupta*

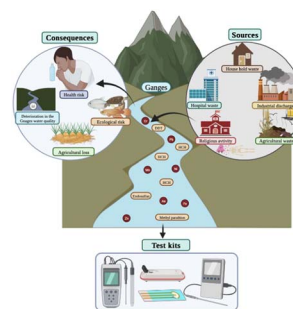

PERSPECTIVE

432

Unlocking the holy grail of sustainable and scalable mesoporous silica using computational modelling

Tom Stavert, Siddharth V. Patwardhan, Robert Pilling
and Miguel Jorge*



COMMUNICATIONS

439

Acrolein-free synthesis of polyacrolein derivatives via the chemo-selective reduction of polyacrylates

Li-Chieh Chou, Kenji Takada, Tatsuo Kaneko,
Naoki Asakawa and Ryohei Kakuchi*



446

Mechanocatalytic depolymerization of hemicellulose to low molecular weight oligosaccharides over an aquivion ionomer

Jonathan Fabian Sierra Cantor, Karine De Oliveira Vigier,*
Gilles Labat, Denilson Da Silva Perez
and François Jérôme*

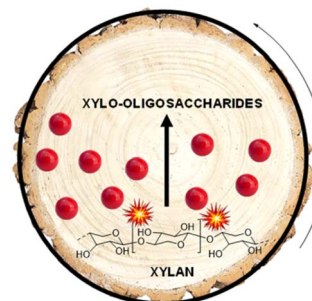

COMMUNICATIONS

454

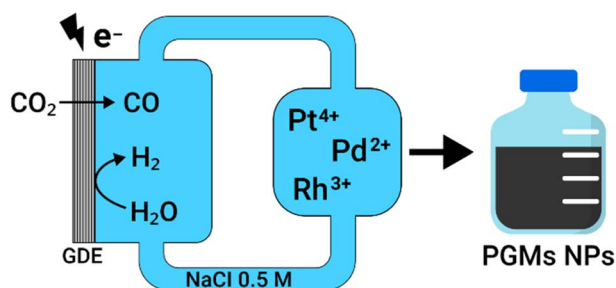

Synthesis of platinum group metal nanoparticles assisted by CO₂ reduction and H₂ cogeneration at gas-diffusion electrodes

Omar Martinez-Mora, Guillermo Pozo, Luis Fernando Leon-Fernandez, Jan Fransaer and Xochitl Dominguez-Benetton*

PAPERS

459

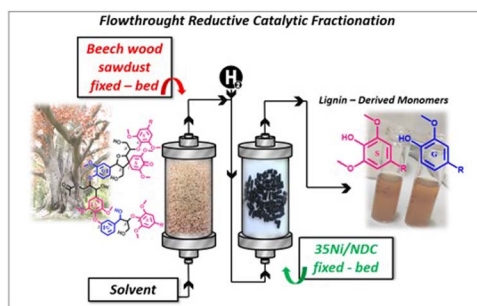

Flow-through reductive catalytic fractionation of beech wood sawdust

Francesco Brandi, Bruno Pandalone and Majd Al-Naji*

470

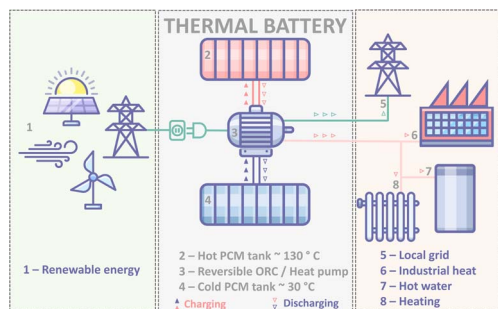

Sustainable materials for renewable energy storage in the thermal battery

Samantha L. Piper, Craig M. Forsyth, Mega Kar, Callum Gassner, R. Vijayaraghavan, S. Mahadevan, Karolina Matuszek,* Jennifer M. Pringle and Douglas R. MacFarlane*

481

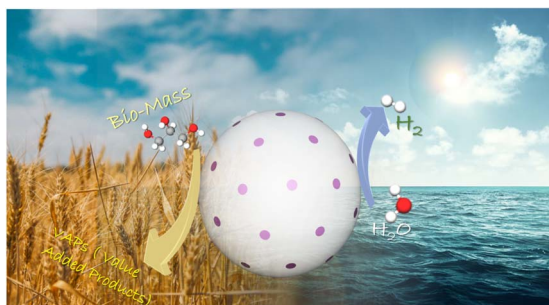

Biomass components toward H₂ and value-added products by sunlight-driven photocatalysis with electronically integrated Au^{δ-}-TiO₂: concurrent utilization of electrons and holes

Himanshu Bajpai, Inderjeet Chauhan, Kranti N. Salgaonkar, Nitin B. Mhamane and Chinnakonda S. Gopinath*



494

Highly selective CO₂ photoreduction to CO on MOF-derived TiO₂

Matthew Garvin, Warren A. Thompson, Jeannie Z. Y. Tan, Stavroula Kampouri, Christopher P. Ireland, Berend Smit, Adam Brookfield, David Collison, Leila Negahdar, Andrew M. Beale, M. Mercedes Maroto-Valer, Ruairaidh D. McIntosh* and Susana Garcia*

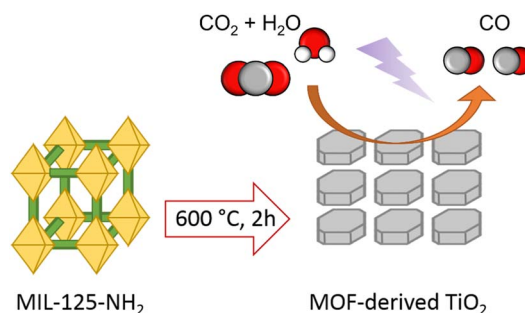

504

Solvent-free synthesis of chalcones using Mg(HSO₄)₂

Ervis Saraci, Massimiliano Andreoli, Emanuele Casali, Massimo Verzini, Maria Argese, Roberto Fanelli and Giuseppe Zanoni*

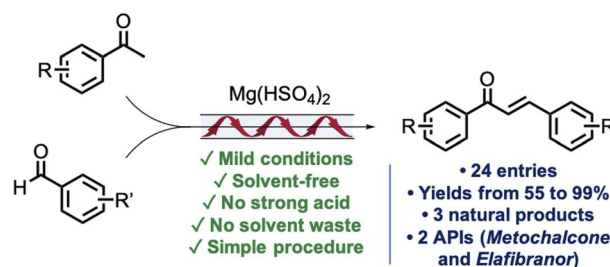

511

Super-fast iodine capture by an ionic covalent organic network (iCON) from aqueous and vapor media

Prince, Atikur Hassan, Sohom Chandra, Akhtar Alam and Neeladri Das*

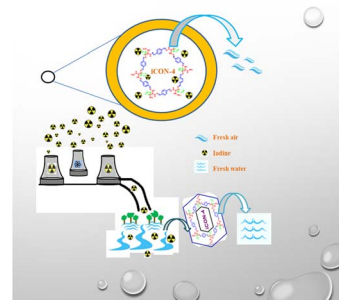

523

Co₃O₄ quantum dot decorated polypyrrole nanocomposites as a flexible, conducting, anticorrosive and antibacterial agent: sustainable experimental and theoretical approach

Harish Kumar,* Manisha Luthra, Manisha Punia, Pawanvir Kaur and Ramesh Kumar

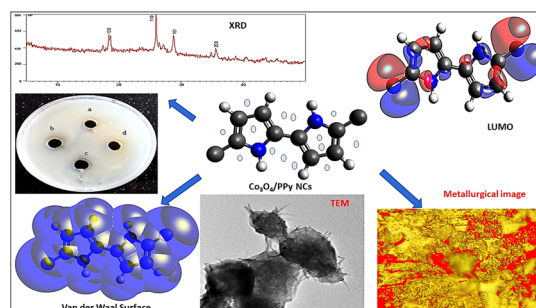

535



Detoxification of bisphenol A via sulfur-mediated carbon–carbon σ -bond scission

Timmy Thiounn, Menisha S. Karunarathna, Moira K. Lauer, Andrew G. Tennyson* and Rhett C. Smith*

543

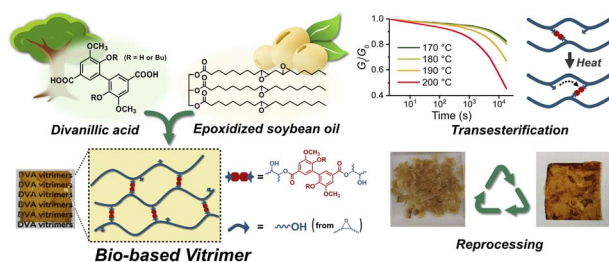

Bio-based vitrimers from divanillic acid and epoxidized soybean oil

Yunfan Zhang, Enomoto Yukiko and Iwata Tadahisa*

554

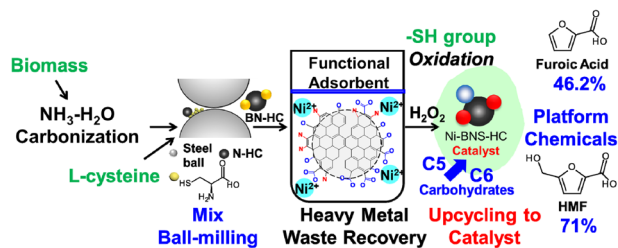

Upcycling of spent functional biocarbon adsorbents to catalysts for the conversion of C5/C6 carbohydrates into platform chemicals

Haixin Guo,* Yuto Inoue, Yukiya Isoda, Tetsuo Honma and Richard Lee Smith, Jr*

563



Circular valorization of coffee silverskin through supercritical CO₂ for the production of functional extracts

Stefania Marzorati,* Amparo Jiménez-Quero, Alessio Massironi, Rita Nasti and Luisella Verotta



574

A polysulfide-functionalized separator enables robust long-cycle operation of lithium-metal batteries

Mengqiu Yang, Yuanpeng Ji, Yunfa Dong, Shijie Zhong, Haodong Xie, Yuanpeng Liu, Caomeng Zhang, Sue Hao, Chunhui Yang, Jiecai Han and Weidong He*

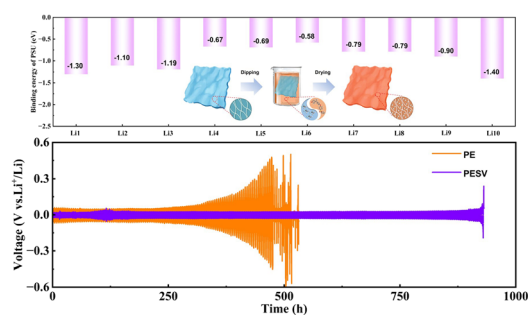

584

Formulation of biobased soap gels from waste-derived feedstocks

Ashley Gambardella, Christian Machado, Melanie Yunga, Jangelis Diaz, Mia Serrano and Julian R. Silverman*

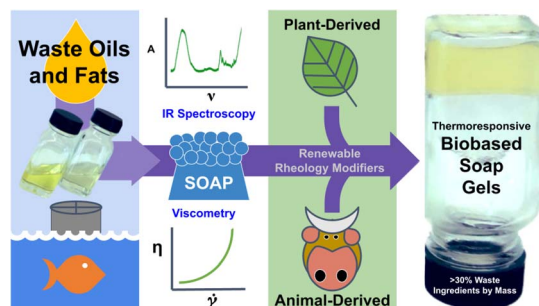

592

A green process for the synthesis of porous TiO₂ from ilmenite ore using molten salt alkali decomposition for photocatalytic applications

Shaik Saida,* Deepak Kumar Gorai and Tarun Kumar Kundu

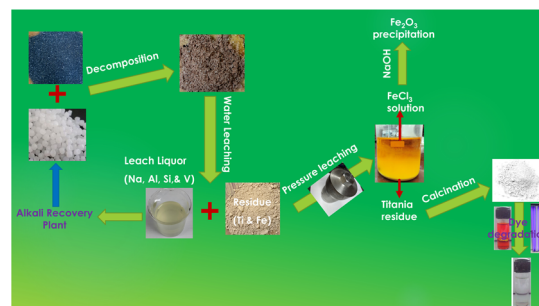

599

Aerosol-assisted sol-gel synthesis of mesoporous Ag-Ta-SiO₂ catalysts for the direct upgrading of ethanol to butadiene

Denis D. Dochain, Antoine Van Den Daelen, Ales Styskalik, Vit Vykoukal and Damien P. Debecker*

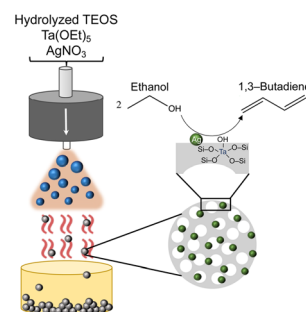

609

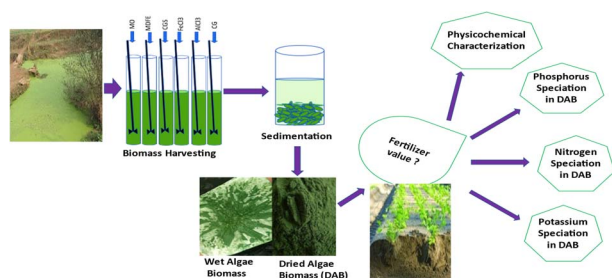

Establishing the nexus between the coagulant for microalgae harvesting and the biomass nutrient assemblage

Toyin Dunsin Saliu, Olayinka John Akinyeye, Yetunde Irinyemi Bulu, Isiaka Ayobamidele Lawal, Isaac Ayodele Ololade and Nurudeen Abiola Oladoja*

622

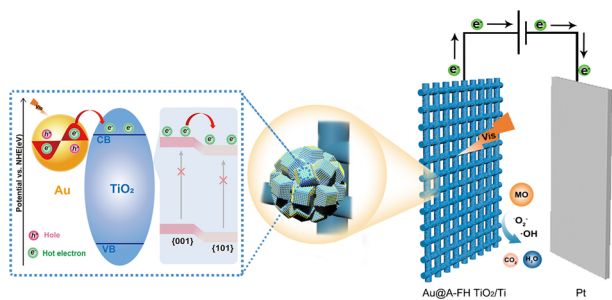

Dual heterojunction-based Au@TiO₂ photoelectrode exhibiting efficient charge separation for enhanced removal of organic dye under visible light

Pan Zhang, Yuzhou Jin, Mingfang Li, Xuejiang Wang and Ya-nan Zhang*

631

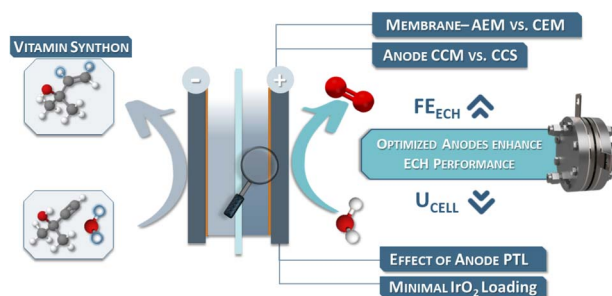

Both sides matter: anode configurations alter the activity of electrolyzers for organic hydrogenations

Kevinjeorjios Pellumbi, Jonas Wolf, Sangita Conjeevaram Viswanathan, Leon Wickert, Mena-Alexander Kräenbring, Julian T. Kleinhaus, Kai Junge Puring, Fatih Özcan, Doris Segets, Ulf-Peter Apfel* and Daniel Siegmund*

640

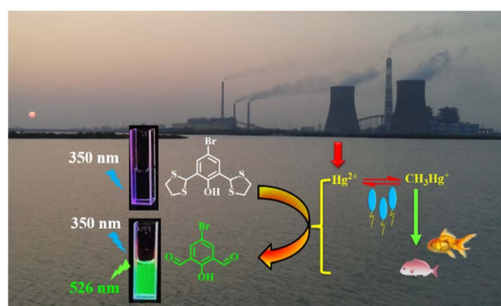

Engineering a bromophenol derivative for rapid detection of Hg²⁺/CH₃Hg⁺ in both environmental and biological samples through a unique activation process

Tapendu Samanta, Narayan Das, Diptendu Patra, Pawan Kumar and Raja Shunmugam*

