



Cite this: *Digital Discovery*, 2024, 3, 674

Accelerated screening of carbon dioxide capture by liquid sorbents†

Ryan J. R. Jones,^a Yungchieh Lai,^a Kevin Kan,^a Dan Guevarra,^a Joel A. Haber,^a Natalia M. Ramirez,^b Alessandra Zito,^b Clarabella Li,^b Jenny Y. Yang,^b Aaron M. Appel,^c and John M. Gregoire^{*a}

The ideation of carbon capture, concentration, and utilization technologies is establishing a need for carbon dioxide sorbents with specific binding, release, and chemical specifications. While computational workflows can help navigate the broad search space of molecular sorbents, automated experimental screening platforms are relatively underdeveloped. We present a carbon capture screening instrument to characterize the carbon dioxide binding and sorption capacity of liquid sorbent media. We discuss the extension of this capability to characterize the loaded liquid sorbent as well as the headspace to facilitate study of the carbon dioxide adduct, for example its electrochemical activation. The fabrication and computer automation instructions are provided so that the experimental technique can be implemented in a broad range of materials acceleration platforms involving gas sorption.

Received 3rd December 2023
Accepted 23rd February 2024

DOI: 10.1039/d3dd00232b

rsc.li/digitaldiscovery

Introduction

The efficient sorption of CO₂ from dilute gas streams is a critical process for enabling carbon sequestration and sustainable energy technologies.^{1,2} McDannald *et al.*³ presented the value proposition for developing a materials acceleration platform (MAP)⁴ for discovery of CO₂ sorbents, and recent advancements in computational predictions⁵ highlight the need for an automated experimental screening instrument. Thermogravimetric analysis (TGA)⁶ is a traditional method for measurement of CO₂ sorption, where the weight-change of a sorbent in a CO₂-containing atmosphere is assumed to be due to CO₂ sorption after calibrating and accounting for solvent evaporation. TGA is particularly convenient for studying sorbents for thermal CO₂ release, as the temperature-dependence of CO₂ binding is readily measured *via* temperature control in the system. For sorbents that are intended to be electrochemically regenerated⁷ and/or used in reactive capture and conversion (RCC) schemes *via* electrochemical reduction to carbon-containing chemicals or fuels,⁸ it is desirable to couple the sorption experiment with an electrochemical cell. While a wetted wall column⁹ system may be adapted for such purposes, the engineering in such systems is focused on

quantitative control of the liquid–gas interface to monitor sorption kinetics, requiring relatively large liquid sorbent volumes and posing challenges for rapid system cleaning. We present herein the carbon capture screening instrument (CCSI), which characterizes CO₂ sorption *via* an infrared measurement of the partial pressure of gas-phase CO₂. While detailed infrared spectroscopy measurements can be used to observe the speciation of sorbed CO₂ as well as molecular CO₂,¹⁰ the CCSI employs a relatively inexpensive sensor from Gas Sensing Solutions. The CCSI instrument also interfaces to automated preparation of liquid sorbent media. The target use is for screening of molecular sorbents. While robotic coupling to molecular synthesis instruments may be developed in the future, the present work discusses the mixture of sorbent-loaded solvent with co-solvents or additives, which have been shown to considerably modify the sorption behavior.¹¹ After the custom preparation of the sorbent media and characterization of its CO₂ sorption characteristics, the CCSI is design to enabled automated transfer of both the liquid and gas phases to instrumentation for further analysis. For RCC experiments, this liquid analysis is intended to be electrochemical characterization, although that capability is not demonstrated in the present work. Herein we introduce the CCSI design, demonstrate its operation with hydroxide solutions, and present an initial screening experiment for a phenoxide sorbent. The ESI† includes pseudo-code for operation, Python code for incorporation into the HELAO-async¹² instrument control platform, a fabrication guide, machining instructions for custom parts, computer drawings, and a parts list with estimated pricing.

^aDivision of Engineering and Applied Science, California Institute of Technology, Pasadena, CA 91125, USA. E-mail: gregoire@caltech.edu

^bDepartment of Chemistry, University of California, Irvine, California 92697, USA

^cInstitute for Integrated Catalysis, Pacific Northwest National Laboratory, Richland, Washington 99352, USA

† Electronic supplementary information (ESI) available: Molecular sorbent synthesis data, CCSI assembly instructions, CCSI automation using helao-async, and CCSI bill of materials. See DOI: <https://doi.org/10.1039/d3dd00232b>



Results and discussion

The carbon capture screening instrument

The CCSI instrument is shown in Fig. 1a with the liquid and gas handling diagram shown in Fig. 1b. The system is designed to measure the partial pressure of CO₂ in the headspace (p_{CO_2}) using an infrared sensor while the headspace is bubbled through the liquid sorbent media *via* the recirculation pump, which accelerates gas-liquid equilibration. Starting from a given amount of CO₂ in the headspace, the CCSI can be operated in a “constant moles” mode in which the sensor measures the rate of sorption of CO₂ from the headspace. A thermodynamic assessment of the CO₂ sorption in this operating mode relies on precise measurement of p_{CO_2} , especially at low partial pressures. Alternatively, CCSI can be operated in a “constant pressure” mode by implementing a feedback loop to inject CO₂ into the headspace to maintain a constant p_{CO_2} . This mode of operation is preferred for characterizing sorption thermodynamics, as discussed further below. We also note our anecdotal observation that reliable measurement of the low p_{CO_2} values encountered in “constant moles” mode required frequent sensor calibration, which is undesirable for deployment of CCSI for accelerated sorbent screening. While CCSI may accommodate experiments at various total pressures, the present work is limited to near-ambient (1 atm) headspace pressure. A total pressure gauge is included in the system, although the data from this sensor is not used in the present work.

The high-level steps of the CCSI instrument for each experiment cycle are shown in Fig. 1c, and the pseudo-code showing the granular execution of these steps is provided in the ESI.† The liquid sorbent for each CCSI experiment is automatically prepared *via* programmed injection into the sorption chamber from 1 or more syringe pumps. The headspace is prepared prior to the injection of the liquid sorbent, and the sorption experiment is considered to start at the initiation of the sorbent injection into the recirculation cell. After liquid injection, the recirculation pump is activated for the duration of the measurement, which is 1 hour for most measurements in the present work. We note that within a couple minutes, the data exhibits whether there is substantial CO₂ sorption from the given headspace, although for the present work we conduct longer experiments to observe the path toward gas-liquid equilibration. As noted in Fig. 1c, the experiment cycle concludes by extraction of the liquid and purging of the instrument.

The headspace for each CCSI experiment is prepared in one of 2 ways. A gas cylinder with $9.85 \pm 0.2\%$ CO₂ in N₂ from Airgas provides the standard process gas. Flushing the system with this gas, injecting the liquid sorbent, and sealing the system provides the initial state where the moles of CO₂ in the system is limited to the headspace volume at 0.099 atm CO₂. The amount of CO₂ sorbed by the liquid (m_{CO_2}) is then determined by the CO₂ added to the system *via* the mass flow controller (MFC) to maintain this p_{CO_2} .

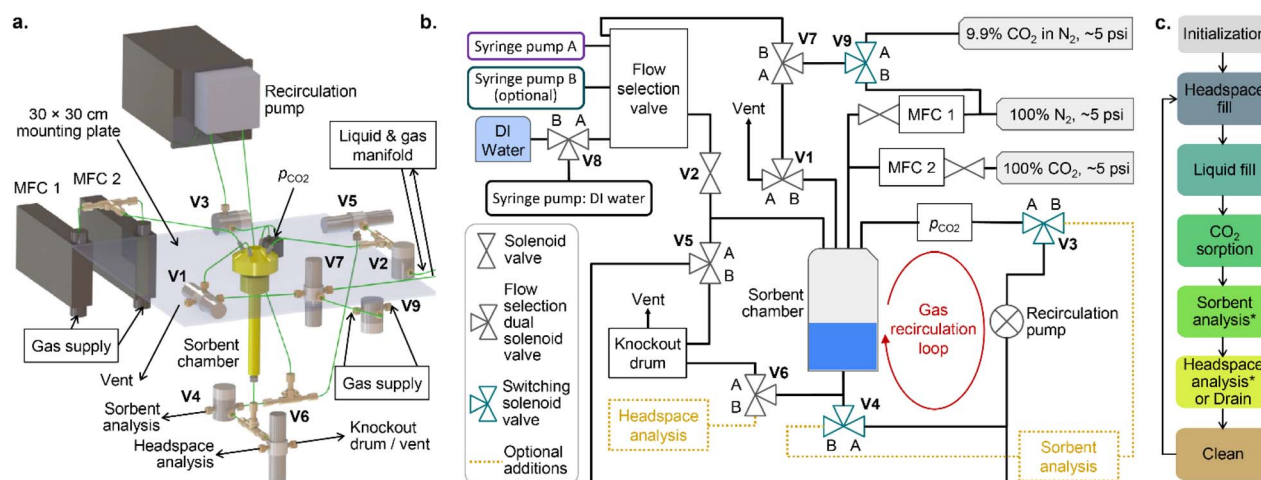

Fig. 1 The Carbon Capture Screening Instrument (CCSI). (a) The computer drawing of the primary components shows the valve and pump layout for automating headspace and liquid sorbent preparation, execution of the sorption experiment under constant partial pressure of CO₂, and post-sorption characterization of the sorbent and/or headspace. (b) The CCSI schematic further outlines the gas and liquid handling system including “Syringe pump A”, which houses the primary sorbent media, and the sorbent media preparation may be expanded using additional syringe pumps accommodated by the flow selection valve. The base solvent, which is deionized water in the present work, is heavily used during cleaning procedures, motivating its integration with a reservoir for automated syringe refill. The analogous gas used for system flushing and headspace initialization is either N₂ or a chosen CO₂ gas mixture. Additionally, CO₂ and N₂ gases provided by mass flow controllers (MFCs) enable controlled dosing of the headspace. The MFCs have integrated solenoid valves, with the CO₂ valve in an upstream configuration because this MFC has an integrated total pressure sensor for auxiliary monitoring of the system. The primary recirculation loop for sorption measurements is highlighted in red. The valving configuration for optional additions to the system are shown, including a recirculation loop for sorbent analysis and a flow-through knockout drum for headspace analysis. (c) The high-level states for CCSI operation are shown where the optional post-sorption analyses are marked (*). After initialization, automated execution of the sample loop can be used to characterize various sorbent formulations, gas compositions, and or post-sorption analyses.



If there are multiple values of p_{CO_2} that will be routinely used, custom gases may be prepared accordingly and selected as the source gas for this primary method of preparing the headspace. In our standard operation, we occasionally use lower pressures of CO_2 , e.g. 1% or 0.1%, which we prepare *via* an alternative method wherein the atmosphere is initialized with pure N_2 . After liquid injection and sealing of the system, the feedback loop for maintaining the setpoint p_{CO_2} is started, where low CO_2 in the headspace results in immediate CO_2 injection. From here, the experiment proceeds as described above, and the calculation of m_{tot} accounts for the CO_2 from the MFC that is in the gas phase.

While m_{tot} quantifies the amount of CO_2 in the liquid phase, the goal of the CCSI experiment is to quantify the chemically bound CO_2 . Thus, m_{tot} is modelled as the sum of the physisorbed unbound CO_2 (m_{phys}), as dictated by Henry's Law coefficient for the solvent, and the chemisorbed CO_2 (m_{chem}).

Demonstration with hydroxide sorbent

To demonstrate the operation of CCSI, two syringe pumps were loaded with deionized water and aqueous 0.2 M KOH solution. The programmed mixing of solutions from these syringe pumps enabled characterization of sorption from aqueous solutions containing 0.02, 0.05, and 0.1 M KOH.

Fig. 2 shows example data for select combinations of $[\text{KOH}]$ and p_{CO_2} where the CO_2 sorption is evidenced by an initial decrease in the p_{CO_2} signal, which triggers periodic injection of CO_2 to eventually restore the headspace to its initial value of p_{CO_2} . For the aqueous KOH experiments, m_{phys} is calculated as the product of the Henry's coefficient for CO_2 in water (0.033 M atm^{-1}) and the p_{CO_2} for the respective experiment. The reaction

of CO_2 and OH^- can result in either carbonate or bicarbonate, whose relative concentration may be determined by measuring the pH of the liquid, where carbonate is the dominant species above $\text{pH} \sim 10$ and bicarbonate is the dominant species below $\text{pH} \sim 10$. Fig. 3 shows the value of m_{chem} with respect to the

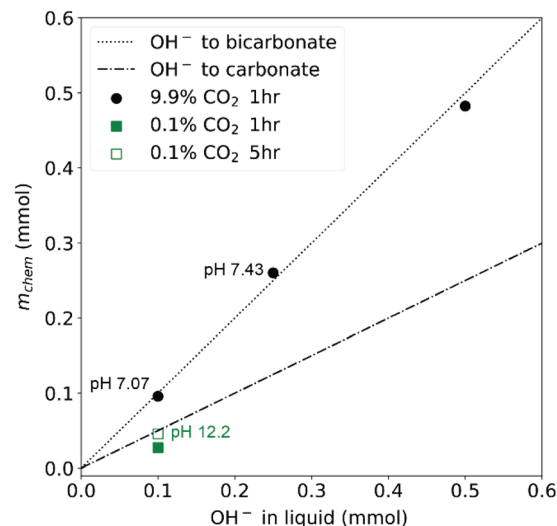

Fig. 3 The data from the four 1 hour experiments in Fig. 2 are summarized to show the relationship between the inferred amount of chemisorbed CO_2 and the amount of OH^- in the initial liquid sorbent. The experiment with lowest $[\text{KOH}]$ and partial pressure was extended to 5 hours, where the measured pH of the liquid sorbent ($\text{pH} 12.2$) corroborates the approximately 1 : 2 ratio of the chemisorbed CO_2 and hydroxide expected for formation of carbonate as the primary dissolved inorganic carbon species. For the other 3 experiments, this ratio is approximately 1 : 1, corresponding to the formation of bicarbonate.

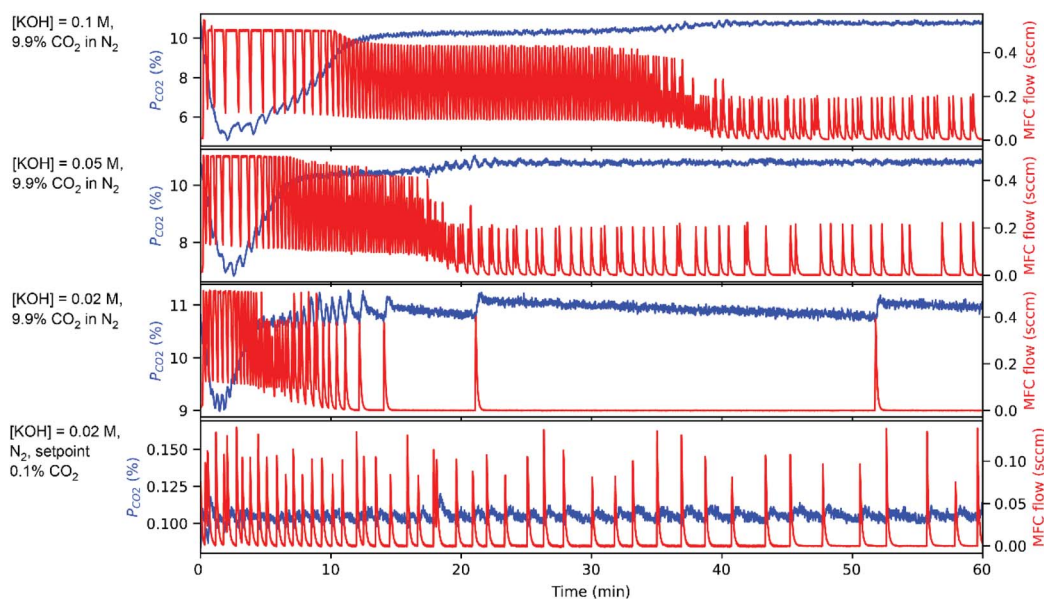

Fig. 2 Sorption data from the CO_2 sensor (left axes) and the MFC (right axes) for 4 experiments with the noted combinations of aqueous $[\text{KOH}]$ and headspace composition. After setting the partial pressure setpoint at the beginning of each experiment, CO_2 sorption by the liquid sorbent triggers injection of pure CO_2 in the headspace, as indicated by the spikes in the MFC flow rate. The stabilization of the partial pressure signal and concomitant lowering of the CO_2 injection frequency indicate that the headspace and liquid sorbent are approaching equilibrium.



loading of KOH for each of the 4 experiments. For 3 of these experiments, the pH was measured after the CCSI experiment. The measurements with 9.9% CO₂ in the headspace follow the expected trend for reaction of OH⁻ and CO₂ to form KHCO₃, which is corroborated by the measurement of near-neutral pH for each liquid. The measurement with 0.1% CO₂ more closely matches the expected value of m_{chem} for the formation of K₂CO₃. Due to the anticipated poor kinetics for equilibration due to the low p_{CO_2} and low initial [KOH], this measurement was extended to 5 hours, after which the measured pH of 12.15 corroborates the formation of carbonate as the primary species of dissolved inorganic carbon.

Screening a molecular sorbent

The primary purpose of the CCSI measurement is to characterize the chemisorption of CO₂ of a sorbent molecule R dissolved into a liquid solvent. If the chemisorbed state of the CO₂ is RCO₂, the equilibrium of RCO₂ with the sorbent R under a CO₂ partial pressure p_{CO_2} is described by the binding constant

$$K = \frac{[\text{RCO}_2]}{[\text{R}]p_{\text{CO}_2}} \quad (1)$$

where p_{CO_2} is a fraction with respect to the standard condition of 1 atm such that K is unitless.¹³ Starting with a molar loading of sorbent m_0 , the CO₂ sorbed during the CCSI experiment (m_{tot}) is adjusted by m_{phys} , which is assumed to be independent of the identity and concentration of R. The resulting amount of chemisorbed CO₂ (m_{chem}) is taken to be the amount of RCO₂. Under these assumptions, the quasi-equilibrium state observed at the end of a CCSI sorption experiment can be described by the apparent binding constant K_{app} calculated from eqn (1):

$$K_{\text{app}} = \frac{m_{\text{chem}}}{(m_0 - m_{\text{chem}})p_{\text{CO}_2}} \quad (2)$$

The error and uncertainty of this quantity will be minimized when the concentrations of R and RCO₂ are approximately equal, which for a given expected binding constant K motivates the choice of

$$p_{\text{CO}_2} \approx \frac{1}{K}$$

However, for a binding constant larger than 10³, which is required for capture from dilute sources of CO₂, the poor transfer kinetics at the corresponding low p_{CO_2} may lead to undesirably long experiment times to equilibrate the liquid sorbent and headspace. For primary screening, we propose using a *ca.* 10% CO₂ atmosphere, which is sufficient to identify the sorbents with binding constants between approximately 10⁻¹ and 10². If m_{RCO_2} is found to be approximately equal to m_0 , then the apparent binding constant is too large to be adequately characterized with $p_{\text{CO}_2} = 9.9\%$, motivating additional experiments with lower values, such as the 0.1% CO₂ atmospheres used in Fig. 2.

Tetramethylammonium pentafluorophenoxide is a novel molecular sorbent, whose synthesis is characterized by nuclear magnetic resonance (NMR) and Fourier transform infrared

spectroscopy (FTIR) in Fig. S1–S5.† Fig. 4 shows the CCSI data for 9.9% CO₂ headspace with aqueous 0.1 M tetramethylammonium pentafluorophenoxide sorbent, corresponding to $m_0 = 0.5$ mmol in the 5 mL aqueous solvent. The p_{CO_2} and CO₂ injection data are shown in Fig. 4, whose analysis provides $m_{\text{tot}} = 0.07$ (mmol) after the ~1 h experiment, with $m_{\text{phys}} = 0.0165$ (mmol) from the presumed free CO₂ physisorbed in the aqueous solvent. We note that m_{tot} reached 80% and 90% of this value after *ca.* 550 and 750 s, respectively, highlighting the opportunity to accelerate sorbent screening as needed.

Following the analysis of eqn (2), the $m_{\text{chem}} = 0.0542$ mmol corresponds to an apparent binding constant $K_{\text{app}} = 1.35$. While this value is insufficient for applications such as direct air capture, the rapid acquisition of this value from an automated system demonstrates the ability of the CCSI instrument to accelerate sorbent discovery efforts.

Safety and build validation

Provided adherence to standard safety practices regarding compressed gasses, the chemical components of the sorbent media, and the control electronics, we do not envision any safety hazards that emerge from the CCSI design. While the CCSI is intended to operate at total pressures near 5 psi above ambient, the use of pressure-relieving regulators can help mitigate exposure of the user and equipment to unsafe pressures. Given the intended use as a screening tool for novel chemical sorbents, the primary safety evaluation for implementation of the CCSI in research workflows involves any chemical hazards of the sorbent media. For example, the KOH-based sorbent media demonstrated herein requires adherence to handling of caustic media.

While component-level operation instructions are provided in the ESI,† we recommend the following evaluations to validate the CCSI assembly. The first validation is against atmospheric leaks, which can be performed by purging the system with N₂ gas until the CO₂ sensor reaches its noise floor, following by sealing the headspace and recirculating the gas using the recirculation pump. The CO₂ sensor time series should then characterize the leak rate of CO₂ in the system, which should be below 10 ppm s⁻¹, although the acceptable rate depends on the intended system use with respect to sorption strength, p_{CO_2} , and measurement duration. The analogous experiment can be performed with the standard gas intended for sorbent screening, *i.e.* 9.9% CO₂ in the present work, where any decline in the measured p_{CO_2} during sealed headspace recirculation indicates a leak to atmosphere. In both cases, we note that the diffusion of gasses through plastic tubing may provide an apparent nonzero leak rate. With the gas handling validated, we recommend that the first set of sorption experiments involve a known strong sorbent. For example, reproduction of Fig. 3 by performing the experiments shown in Fig. 2 should provide sufficient quantitative characterization of the CCSI to enable subsequent characterization of novel sorbents.

Adaptions and additional considerations

We note that for all experiments in the present work, p_{CO_2} was determined by using the premixed 9.9% CO₂ gas or by dosing



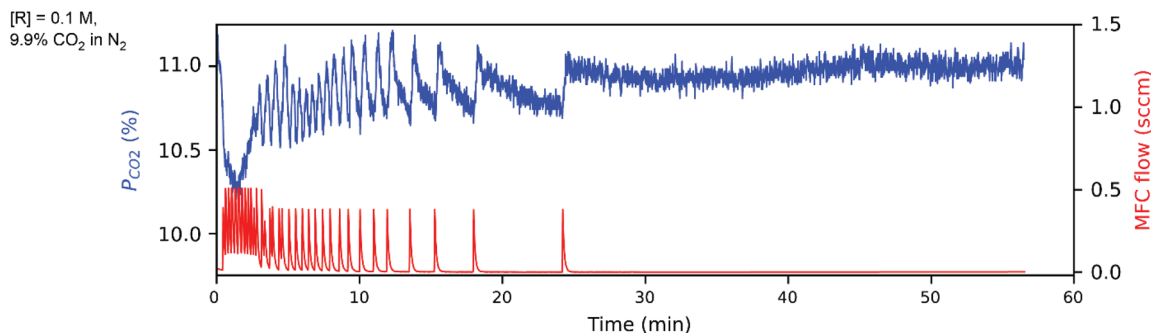

Fig. 4 The CCSI data for the sorption of CO₂ from a 9.9% atmosphere by an aqueous 0.1 M tetramethylammonium pentafluorophenoxide sorbent. The headspace was initialized using a pre-prepared gas with 9.9% CO₂, which is taken to be the true partial pressure in the headspace. The sensor reports approximately 11% partial pressure, but since this value is only used as the setpoint for maintaining constant partial pressure, the numerical evaluation of CO₂ sorption is provided by the amount of CO₂ from the MFC injection into the headspace, which concludes after an apparent equilibrium is reached after 25 minutes of gas recirculation through the liquid sorbent.

a pure N₂ to obtain 0.1% CO₂. In the former preparation, the reading from the CO₂ sensor is recorded after the headspace is prepared, providing the setpoint value for the feedback control of the CO₂ injections. With this method, the absolute accuracy of the CO₂ sensor is inconsequential. We anecdotally observed that the absolute reading can drift. For automated execution of lower p_{CO_2} experiments, e.g. 0.1%, the zero-level of the sensor should be calibrated in the pure N₂ atmosphere to ensure accurate preparation of the gas *via* MFC feedback to the setpoint p_{CO_2} .

The MFC control algorithm used in the present work is relatively simple and designed to mitigate the over-pressurization of CO₂ in the system. We believe that the gas-liquid exchange kinetics are the limiting factor for experiment throughput, although we note the opportunity for increasing the efficiency of p_{CO_2} through, for example, a proportional-integral-derivative (PID) controller.

The CCSI system provides the ability for post-sorption analysis of the sorbent media. In the present work, this analysis is limited to manual pH measurements. Fig. 1b illustrates the valve configuration for implementing post-sorption characterization of the CO₂-loaded liquid and headspace gas. These steps are noted as optional in Fig. 1c, and the pseudo-code provided in the ESI† includes the steps for executing such post-sorption analyses, as well as the additional cleaning steps.

To the best of our knowledge, there is no commercial analogue to the CCSI instrument, with automated preparation of sorbent media, execution of sorption characterization, and triggering subsequent liquid and gas analyses. The design employed herein offers a relatively inexpensive set of components, as detailed in the ESI.† Compared to a TGA instrument, which can cost upwards of 10 000 U.S.D., the CCSI components are comparable and possibly lower depending on factors such as availability of an existing computer, the chemical compatibility of components (the present build can handle aqueous and nonaqueous solvents, while several valve and tubing components may be replaced with less expensive alternatives for aqueous-only operation), and the sorbent media preparation manifold. The biggest variable in the system cost is the choice of

recirculation pump, which can be *ca.* 1000 U.S.D. for an inexpensive peristaltic pump using tubing with limited chemical compatibility, to *ca.* 4000 U.S.D. for a diaphragm pump with PEEK tubing, which increases chemical compatibility and enables pumping of viscous sorbent media. We note that in the present work the recirculation pump acts only on the headspace, but we envision pumping on the liquid sorbent in subsequent electrochemical characterization using a recirculation cell design that we previously reported.¹⁴ We have built multiple versions of the CCSI with different choices of pumps to meet different specifications of the sorbent media. To our knowledge, no similar instrument has been replicated in an independent laboratory.

Experimental

The parts list and assembly instructions are provided in the ESI.† The tubing used for the primary data include primarily polyether ether ketone tubing with a short segment of Viton tubing used in the 300 rpm Masterflex C/L 77122-24 peristaltic pump for recirculation. To avoid the use of the soft-walled tubing and to expand the chemical compatibility of the system, the pump can be replaced with, for example, a KNF SIMDOS 02 diaphragm pump. The CO₂ sensor is a Gas Sensing Solutions SprintIR6S-20. Reported pH measurements were acquired with an OAKTON PC700 pH meter. Additional custom machined parts are described in the ESI.†

The 18.2 MΩ water used to prepare all sorbent media was from a Millipore Milli-Q Advantage A10. The KOH solution was prepared *via* dissolution of KOH pellets (Macron Fine Chemicals, AR-ACS). The two pure gases are 99.999%, 99.998% for CO₂ and N₂, respectively, and the gas mixture is 9.85 ± 0.2% CO₂ in N₂ (airgas).

Synthetic work was carried out in ambient air and environment. All solvents and reagents were purchased from commercial vendors and used without further purification unless otherwise noted. Deuterated DMSO used for NMR characterization was purchased from Cambridge Isotope Laboratories, Inc., as was degassed *via* the free-pump-thaw



method and stored over activated 3 Å molecular sieves in a glovebox.

Fourier Transform Infrared (FTIR) spectroscopy was performed using a Thermo Scientific Nicolet iS5 FTIR Spectrometer with iD5 diamond ATR. ^1H , $^{13}\text{C}\{^1\text{H}\}$, and $^{19}\text{F}\{^1\text{H}\}$ NMR and spectra were recorded on a 600 MHz Varian instrument. ^1H and ^{13}C NMR spectra chemical shifts are reported as δ values in ppm relative to the residual solvent (CD_3)₂SO (2.50 ppm, ^1H , and 39.52 ppm, ^{13}C).

Tetramethylammonium 2,3,4,5,6-pentafluorophenolate was synthesized and characterized as follows. Pentafluorophenol (1.672 g, 9 mmol) was weighed out and added to a vial containing 25% w/w tetra(*n*-methyl)ammonium hydroxide (3.298 g, 9 mmol) and methanol (2 mL). This mixture was stirred at room temperature overnight. The resulting solution was dried using a rotary evaporator and then dried further on a high vacuum pump on a Schlenk line overnight. The product is a fine white powder. The product was stored in a nitrogen atmosphere until use, which involved air exposure during the dissolution in water to create the sorbent media. Yield: 2.259 g (97%). ^1H NMR (600 MHz *d*-DMSO) δ 3.14 (TMA) ppm. $^{13}\text{C}\{^1\text{H}\}$ NMR (151 MHz, *d*-DMSO) δ 147.8 (tt, $J = 14.1, 4.0$ Hz), 140.9 (dtdd, $J = 231.9, 9.2, 4.6, 1.9$ Hz), 138.6 (ddtd, $J = 235.9, 19.2, 10.6, 2.3$ Hz), 123.7 (dt, $J = 222.4, 14.8, 5.4$ Hz), 54.4–54.3 (m, TMA) ppm. $^{13}\text{C}\{^1\text{H}\}$ NMR (151 MHz, D_2O) δ 142.0–141.7 (m), 140.8 (dm, $J = 231.6$ Hz), 138.2 (dm, $J = 240.7$ Hz), 129.8 (dm, $J = 232.4$ Hz), 55.3–55.2 (m, TMA) ppm. $^{19}\text{F}\{^1\text{H}\}$ (565 MHz, *d*-DMSO) δ –172.0–172.1 (m, 2F), –172.1–172.3 (m, 2F), –196.3–196.5 (m, 1F) ppm. FTIR (ATR)/ cm^{-1} $\nu = 3032.41$ (w), 1690.86 (w), 1644.75 (w), 1599.17 (w), 1504.13 (s), 1487.98 (s), 1467.75 (s), 1248.42 (m), 1230.19 (m), 1167 (w), 1084.29 (w), 1046.34 (w), 1001.62 (s), 967.89 (s), 723.23 (w), 604.91 (w), 577.75 (w).

Conclusions

We present an automated instrument for characterization of carbon dioxide capture from a headspace into liquid sorbent media. The instrument interfaces sorption characterization with automated preparation of the liquid sorbent and headspace gas, as well as extension of the instrument for subsequent characterization of the liquid and gas. Characterization of aqueous tetramethylammonium pentafluorophenoxide revealed an apparent binding constant (on a pressure basis) of 1.35, demonstrating deployment of the instrument to characterize novel sorbent–solvent combinations, a critical component of a materials acceleration platform for accelerating the development of carbon capture, concentration, and utilization technologies.

Data availability

The instrument control software is available at <https://github.com/High-Throughput-Experimentation/helao-async>, with dependencies in <https://github.com/High-Throughput-Experimentation/helao-core>. The computer drawings of the instrument, instrumentation control software (helao snapshot), the data files acquired for the present work, and

the source code for the analysis and plotting of those data are provided *via* CaltechData at <https://data.caltech.edu/records/5z5zz-m9r81> (doi: 10.22002/5z5zz-m9r81). The license for the CCSI hardware is included alongside the design files in that repository, as well as a ESI document† for this manuscript.

Author contributions

R. J. J. and J. M. G. designed the CCSI with input from J. Y. Y., A. M. A., and J. A. H. R. J. J. and K. K. assembled and validated the CCSI. R. J. R., K. K., and D. G. developed the instrument control software with validation experiments by K. K. and Y. L. Y. L. operated CCSI and analyzed its data. C. L. and N. M. R. synthesized and characterized the phenoxide sorbent under supervision of J. Y. Y. J. M. G. was the primary author of the manuscript with contributions from all authors. R. J. R., K. K., and Y. L. were the primary authors of the assembly and operation instructions.

Conflicts of interest

A patent application for the CCSI has been filed. J. M. G. is an industrial consultant for experiment automation.

Acknowledgements

This material is based upon work performed by the Center for Closing the Carbon Cycle, which is supported by the U.S. Department of Energy, Office of Science, Office of Basic Energy Sciences Energy Frontier Research Centers program under Award Number DE-SC0023427.

Notes and references

- X. Wang and C. Song, *Front. Energy Res.*, 2020, **8**, 560849.
- A. M. Appel, J. E. Bercaw, A. B. Bocarsly, H. Dobbek, D. L. DuBois, M. Dupuis, J. G. Ferry, E. Fujita, R. Hille, P. J. A. Kenis, C. A. Kerfeld, R. H. Morris, C. H. F. Peden, A. R. Portis, S. W. Ragsdale, T. B. Rauchfuss, J. N. H. Reek, L. C. Seefeldt, R. K. Thauer and G. L. Waldrop, *Chem. Rev.*, 2013, **113**, 6621–6658.
- A. McDannald, H. Joress, B. DeCost, A. E. Baumann, A. G. Kusne, K. Choudhary, T. Yildirim, D. W. Siderius, W. Wong-Ng, A. J. Allen, C. M. Stafford and D. L. Ortiz-Montalvo, *Cell Rep. Phys. Sci.*, 2022, **3**, 101063.
- M. M. Flores-Leonar, L. M. Mejía-Mendoza, A. Aguilar-Granda, B. Sanchez-Lengeling, H. Tribukait, C. Amador-Bedolla and A. Aspuru-Guzik, *Curr. Opin. Green Sustainable Chem.*, 2020, **25**, 100370.
- Z. Zhang, A. L. Kummeth, J. Y. Yang and A. N. Alexandrova, *Proc. Natl. Acad. Sci. U. S. A.*, 2022, **119**, e2123496119.
- M. Plaza, C. Pevida, B. Arias, J. Feroso, A. Arenillas, F. Rubiera and J. Pis, *J. Therm. Anal. Calorim.*, 2008, **92**, 601–606.
- J. M. Barlow, L. E. Clarke, Z. Zhang, D. Bím, K. M. Ripley, A. Zito, F. R. Brushett, A. N. Alexandrova and J. Y. Yang, *Chem. Soc. Rev.*, 2022, **51**, 8415–8433.



- 8 M. A. Sabri, S. Al Jitan, D. Bahamon, L. F. Vega and G. Palmisano, *Sci. Total Environ.*, 2021, **790**, 148081.
- 9 H. Karlsson and H. Svensson, *Energy Procedia*, 2017, **114**, 2009–2023.
- 10 X. Wang, V. Schwartz, J. C. Clark, X. Ma, S. H. Overbury, X. Xu and C. Song, *J. Phys. Chem. C*, 2009, **113**, 7260–7268.
- 11 J. M. Barlow and J. Y. Yang, *J. Am. Chem. Soc.*, 2022, **144**, 14161–14169.
- 12 D. Guevarra, K. Kan, Y. Lai, R. J. R. Jones, L. Zhou, P. Donnelly, M. Richter, H. S. Stein and J. M. Gregoire, *Digital Discovery*, 2023, **2**, 1806–1812.
- 13 M. Özcan, *J. Phys. Chem. Lett.*, 2022, **13**, 3507–3509.
- 14 R. J. R. Jones, Y. Wang, Y. Lai, A. Shinde and J. M. Gregoire, *Rev. Sci. Instrum.*, 2018, **89**, 124102.

