



## Exploiting Electricity Market Dynamics using Flexible Electrolysis Units for Retrofitting Methanol Synthesis

Journal:	<i>Energy &amp; Environmental Science</i>
Manuscript ID	EE-ART-02-2023-000568.R1
Article Type:	Paper
Date Submitted by the Author:	10-Apr-2023
Complete List of Authors:	Ma, Jiaze; University of Wisconsin, Chemical and Biological Engineering Rebarchik, Michael; University of Wisconsin Madison, Chemical and Biological Engineering Bhandari, Saurabh; The Dow Chemical Company, ; University of Wisconsin-Madison, Chemical and Biological Engineering Mavrikakis, Manos; University of Wisconsin Madison, Chemical and Biological Engineering Huber, George; University of Wisconsin, Chemical and Biological Engineering Zavala, Victor; University of Wisconsin-Madison,

# Exploiting Electricity Market Dynamics using Flexible Electrolysis Units for Retrofitting Methanol Synthesis

Jiaze Ma, Michael Rebarchik, Saurabh Bhandari

Manos Mavrikakis, George W. Huber, Victor M. Zavala\*

Department of Chemical and Biological Engineering, University of Wisconsin-Madison  
1415 Engineering Dr, Madison, WI 53706

## Broader Context

The United States (US) chemical industry consumes roughly 7,000 trillion BTUs of energy annually, accounting for over 10% of the total energy consumption in 2018. As such, the chemical industry contributes a significant fraction of the US greenhouse gas (GHG) emissions, ranking 7<sup>th</sup> amongst anthropogenic contributors. The deepening climate emergency underscores the urgent need to reduce the carbon footprint of manufacturing; key contributors to this footprint are the combustion of fossil fuels and the production of basic feedstocks. A potential decarbonization strategy consists of capturing and converting emitted CO<sub>2</sub> into chemicals (e.g., producing methanol through CO<sub>2</sub> hydrogenation); alternatively, it is also possible to reduce the generation of CO<sub>2</sub> during the production of key feedstocks (such as hydrogen). At the same time, the power grid is also seeking to decarbonize by absorbing more renewable power into the system; however, the intermittency of wind and solar power requires of demand flexibility from manufacturing facility. As such, there are synergistic opportunities that can arise from the electrification of manufacturing.

# Exploiting Electricity Market Dynamics using Flexible Electrolysis Units for Retrofitting Methanol Synthesis

Jiaze Ma, Michael Rebarchik, Saurabh Bhandari

Manos Mavrikakis, George W. Huber, Victor M. Zavala\*

Department of Chemical and Biological Engineering, University of Wisconsin-Madison

1415 Engineering Dr, Madison, WI 53706

**Abstract.** We investigate the economic viability of integrating flexible electrolysis units to produce hydrogen in methanol synthesis processes. Specifically, we investigate whether this approach can help reduce methanol production costs by strategically exploiting dynamics of electricity markets. Our study integrates high-fidelity process simulations, optimization tools, and microkinetic modeling (informed by density functional theory) to conduct detailed techno-economic analyses and to compare performance against traditional processes that use hydrogen produced via steam-methane reforming (SMR). We also use this approach to estimate the levelized cost of hydrogen (LCOH) as a function of time-varying electricity prices (from day-ahead and real-time prices) and of key techno-economic parameters. Our results show that the proposed electrification framework is cost-competitive under certain electricity market conditions. Specifically, we find that, when the electrolysis system is operated in flexible mode (and can respond to dynamics of electricity markets), the associated electricity cost nearly collapses to zero. Conversely, when the unit is not flexible (and cannot respond to markets), the electricity cost comprises 60% of the total cost. Our results also reveal that the LCOH of the flexible electrolysis system participating in real-time electricity markets is 31% lower than the LCOH obtained from SMR. Overall, this indicates that exploiting the dynamics of electricity markets can make hydrogen production cost-competitive and this can lead to viable alternatives to electrify methanol production and other hydrogen-based processes.

**Keywords:** electrification, hydrogen, methanol, energy markets, optimization

**Introduction.** In response to the escalating climate crisis, characterized by increasing temperatures, more frequent extreme weather events, and other catastrophic effects, the Biden administration has taken action to reduce carbon emissions and accelerate the transition to a clean energy economy. These efforts include setting an ambitious target to reduce greenhouse gas pollution by 50-52% below 2005 levels by 2030<sup>1</sup>, which aligns with the recommendations of the National Academies of Sciences, Engineering, and Medicine's report on decarbonization<sup>2</sup>. To further combat climate change, the administration has recently announced a \$6 billion plan to reduce industrial emissions and create healthier communities<sup>3</sup>. These actions demonstrate a strong commitment to securing a sustainable future for all. The United States (US) chemical industry consumes roughly 7,000 trillion BTUs of energy annually, accounting for over 10% of the total energy consumption in 2018<sup>4</sup>. As such, the chemical industry contributes a significant fraction of the US greenhouse gas (GHG) emissions, ranking 7<sup>th</sup> amongst anthropogenic contributors<sup>5</sup>. The deepening climate emergency underscores the urgent need to reduce the carbon footprint of manufacturing; key contributors to this footprint are the combustion of fossil fuels and the production of basic feedstocks. A potential decarbonization strategy consists of capturing and converting emitted CO<sub>2</sub> into chemicals (e.g., producing methanol through CO<sub>2</sub> hydrogenation); alternatively, it is also possible to reduce the generation of CO<sub>2</sub> during the production of key feedstocks (such as hydrogen)<sup>6</sup>. Hydrogen production, in particular, accounts for 3% of the global CO<sub>2</sub> emissions<sup>7</sup>; this is because nearly 50% of all the hydrogen in the world is produced via steam-methane reforming (SMR), which is an energy-intensive process<sup>8</sup>. It is estimated that the global warming potential (GWP) of producing 1 kg of hydrogen via SMR is 11.8 CO<sub>2</sub>-eq kg<sup>9</sup>.

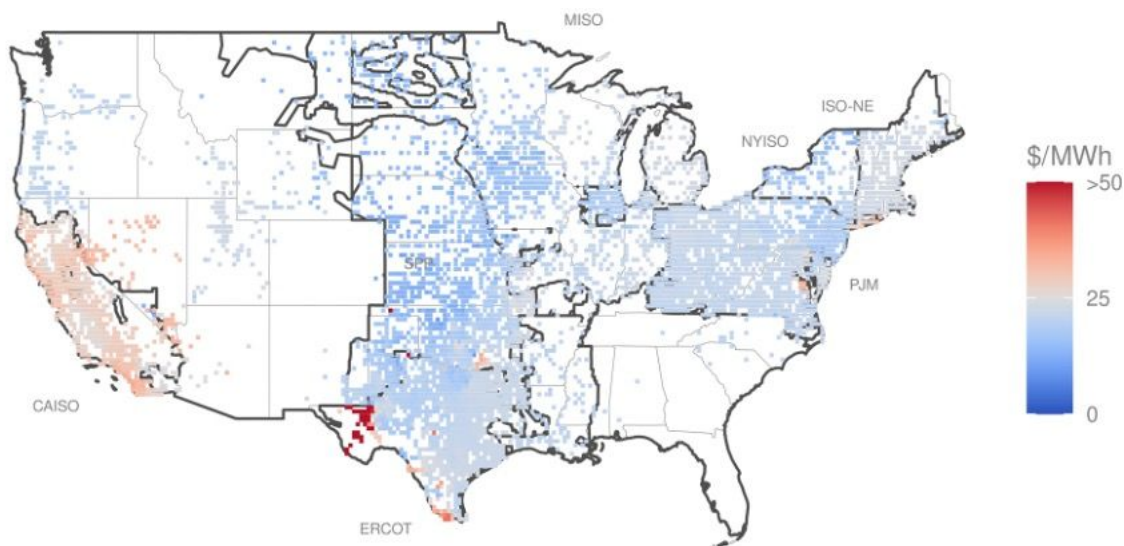
Electrolytic water-splitting (e.g., using low-carbon electricity obtained from renewables) can facilitate the reduction of the CO<sub>2</sub> footprint of hydrogen production. This approach is highlighted in a recent report from the White House, which emphasizes the potential of hydrogen as a critical component of the clean energy transition<sup>10</sup>. In addition, electrolytic water-splitting provides a synergistic approach for helping the power grid balance operations, which is becoming increasingly challenging as more solar and wind power are injected in the grid<sup>11</sup>. According to the US Energy Information Administration (EIA), the share of renewables in the electricity generation was 21% in 2020 and is expected to increase to 42% by 2050 (growth mostly driven by growth in solar/wind power)<sup>12</sup>. The intermittent nature of solar/wind power causes dynamic mismatches of supply/demand in the grid and disrupts market prices and other key operational variables (e.g., frequency and voltages)<sup>13</sup>. Given the increasing share of renewable power in power grid, load (demand) flexibility has become an important operational resource<sup>14</sup>.

Electrification technologies such as Power-to-Gas (PtG) or Power-to-Liquid (PtL) technologies have been identified as promising approaches to provide load flexibility and facilitate integration of renewable power in the grid<sup>15</sup>. Specifically, these units can strategically convert excess power from the grid (or power at low prices) into chemical products, which can then be used during periods of power scarcity (or power at high prices). This Power-to-X concept has been investigated in diverse processes, such as methanol synthesis<sup>16,17,18,19,20</sup>. Producing chemicals using electricity can also provide enormous storage and/or absorption capacities for excess power. As such, the Power-to-X approach provides a pathway to decarbonize the chemical sector and the power grid. Unfortunately, most studied processes have been found to be economically infeasible (primarily due to the high cost of electricity). A set of techno-economic analysis (TEA) studies show that Power-to-X technologies are usually not cost-competitive compared with traditional fossil-based technologies<sup>21,22,23,24</sup>. For instance, producing methanol via an electrified process has been found to be economically unattractive, with the production cost being 1.3-2.6 times higher than that of the current fossil-based counterpart<sup>23</sup>. Hydrogen production has been found to be the most critical factor that affects the economy of electrified variants; meanwhile, 60-70% of the electrolytic hydrogen cost results from electricity supply costs<sup>24</sup>. Consequently, the economic viability of electrified process variants relies heavily on electricity market conditions.

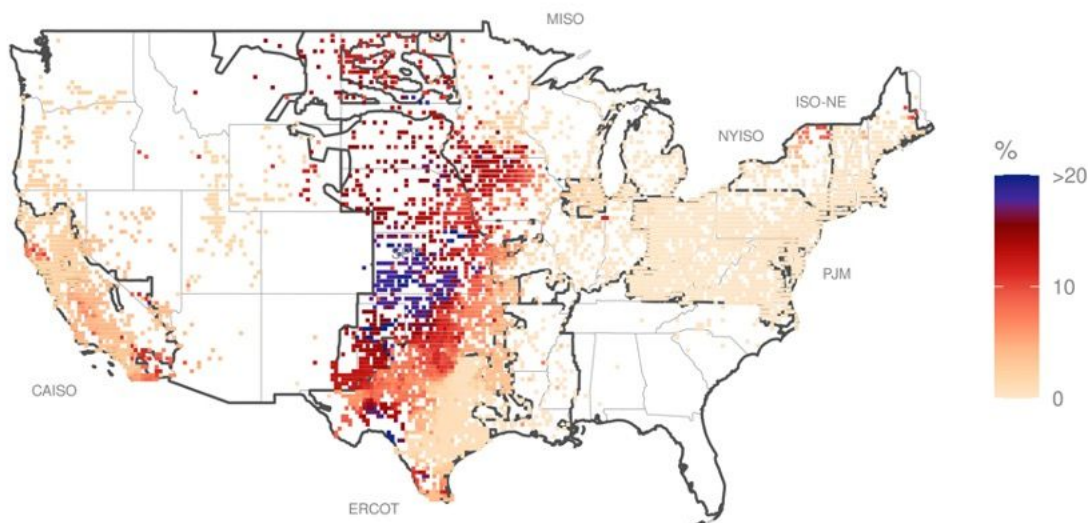
The 2020 average wholesale real time market (RTM) electricity price in the US was 21.03 USD/MWh but significant spatiotemporal variability was also observed (Figure 1a)<sup>25</sup>. In the Midwest region of the US (which includes Kansas, Oklahoma, and Texas) the average wholesale electricity price was in the range of 13.6-19.04 USD/MWh. In Figure 1b, we also observe that the negative price frequency of the wind-rich central region was in the range of 10-20%. These negative prices result from excess power supply and create an economic incentive to use power (users get paid to use power). Figure 2 provides further evidence that US wholesale electricity markets are highly volatile. This volatility is expected to increase as more renewables are injected into the grid. Electricity price volatility also differs by the type of market. For instance, the RTM changes every 15 mins, while the electricity price of the day-ahead market (DAM) varies every hour. The standard deviation of RTM (measure of volatility) is 33% higher than that of the DAM. The high volatility of energy markets is a manifestation of the impact of renewable power fluctuations in grid operations and opens opportunities to deploy flexible, electrified manufacturing systems.

As an essential building block of the modern chemical industry, methanol has diverse end uses such as formaldehyde, acetic acid, olefin, biodiesel, and solvent production. These end uses, in turn, are utilized to create hundreds of everyday products, spanning from plastics, paints, and car parts to construction materials. The global market demand for MeOH has been steadily increasing and reached approximately 100 million tonnes in 2021. The global methanol market also reached a value of US\$ 32.7 Billion in the same year. Looking ahead, the projected compound annual growth rate for the forecast period of 2022-2027 is estimated to be 5.49%<sup>26</sup>. Given the significance of methanol in today's industrial and chemical production processes, in this work, we investigate the economic viability of an electrified methanol process; specifically, we:

- Investigate the economic viability of retrofitting existing methanol processes using flexible electrolysis units for hydrogen production that exploit dynamics of electricity markets.
- Investigate the impact of key techno-economic parameters and of electricity markets on the viability of this approach.
- Identify optimal design and operating modes of the process under diverse market conditions.
- Develop a systematic approach to compute the levelized hydrogen production cost (LCOH) under dynamic electricity prices and under different process efficiencies and capital costs.



(a)



(b)

Figure 1. (a) Average electricity prices for real time markets in the US in 2020. (b) Frequency (percent of times) in which negative electricity prices were observed in the US in 2020<sup>27,28</sup>.

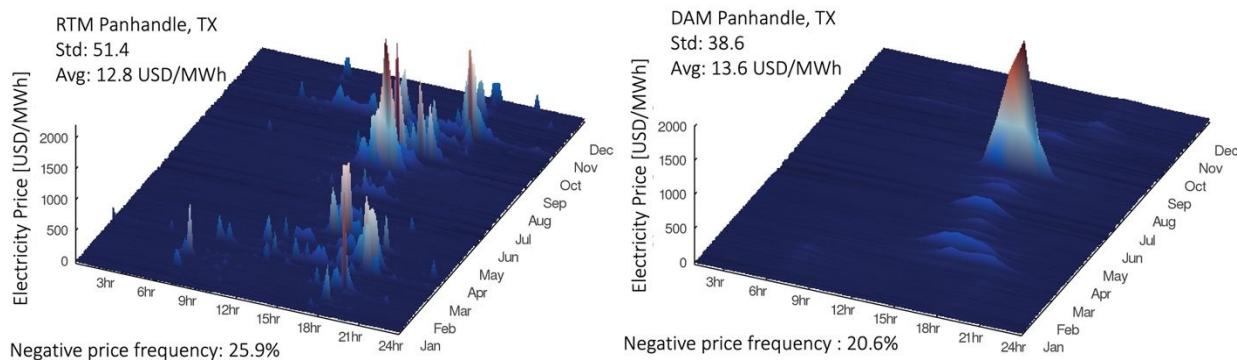


Figure 2. Real-time (left) and day-ahead (right) electricity prices in Panhandle, TX in 2020<sup>29</sup>.

To enable this, we have developed a comprehensive computational framework that integrates detailed process simulation models, microkinetic models (informed by density functional theory), and a multi-period optimization model. This framework is used to determine the optimal sizing and operating strategies of a flexible electrification unit that is compatible with a methanol synthesis process and that is able to respond to dynamics of electricity prices. Our analysis reveals that the economic viability of the proposed approach highly depends on the flexibility of the process and on the market conditions. Specifically, when the system is non-flexible (and cannot adjust operations in response to electricity markets), the electricity cost contributes more than 60% of the total cost and the overall process is not economically viable. On the other hand,

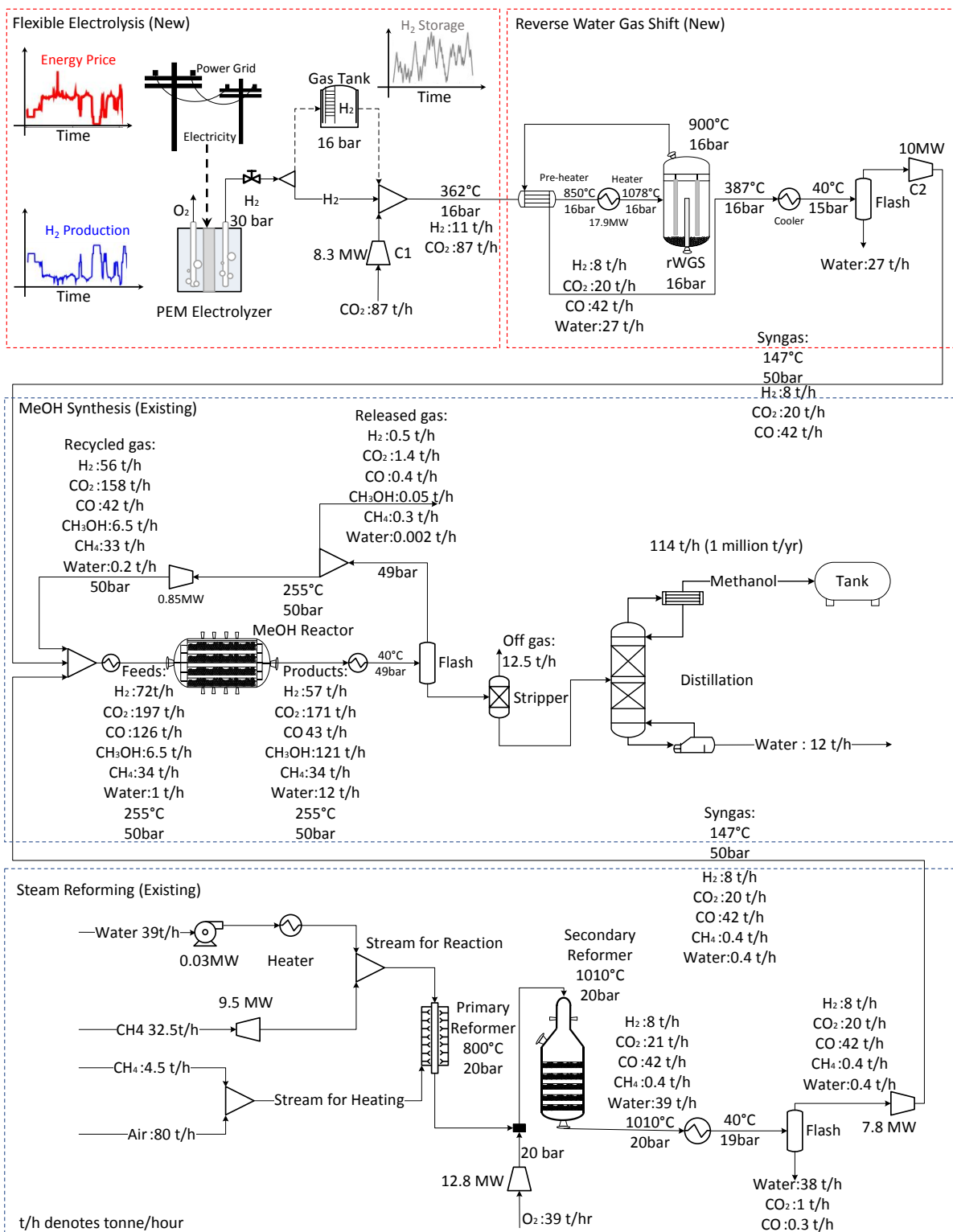
when the system is flexible (and can respond to dynamic electricity markets), the electricity cost *almost collapses to zero* and the overall process is not viable. In comparison with sourcing hydrogen entirely from SMR, implementing the flexible electrification unit leads to a 62 million USD/yr cost reduction for a methanol plant with a capacity of 1 million tonne/yr. The payback period of such retrofitting project is less than eight years. Moreover, we observe that the competitiveness of the electrification unit is sensitive to the natural gas prices. Our analysis also reveals that lowering the capital investment of electrolyzer equipment is more impactful than increasing electrolyzer efficiency; this is important, because the cost of electrolysis units can potentially be decreased as more units are manufactured and deployed (under on-going hydrogen initiatives). Finally, our analysis reveals that the levelized cost of hydrogen (LCOH) using a flexible electrolysis unit that participates in real-time electricity markets can be as low as 0.92 USD/kg, which is 31% lower than the LCOH via SMR under current natural gas prices. This result is surprising and indicates that there can be tangible benefits of producing hydrogen by exploiting time-varying electricity prices and that such benefits can be exploited for other hydrogen-based processes. All market/process data collected and models developed in our study are shared with this manuscript; these can be used to reproduce the results and to conduct additional studies on the potential of electrifying methanol production and other processes.

## Process Description

**MeOH Synthesis with Flexible Electrification.** The methanol synthesis process involves the reaction of carbon monoxide (CO) or carbon dioxide (CO<sub>2</sub>) with hydrogen (H<sub>2</sub>) to generate methanol (MeOH). As with many other chemical processes, synthesis gas required for methanol synthesis is typically generated through SMR. Here, we consider sourcing synthesis gas via the addition of an electrification system that consists of an electrolysis unit and a reverse water shift gas (rWGS) unit. The generated syngas by the electrification system substitutes 50% the syngas produced by the steam reformer. This strategy lowers the consumption of natural gas and the operational cost of the steam reformer. In Figure 3, solid lines are streams that have constant material flows. The dash lines represent streams where material flows change over time. To harness the flexibility of the electricity market, the operating mode of the electrolyzer needs also to be flexible. Specifically, the amount of hydrogen produced at each time interval depends on the electricity price. During off-peak hours, when the electricity price is low, more hydrogen can be produced than is needed and the excess hydrogen is stored in the hydrogen tank. The electrolyzer operates under part-load during the electricity peak hours. The stored hydrogen is released during these periods to meet the constant hydrogen demand of rWGS. With a continuous



supply of hydrogen and  $\text{CO}_2$ , the rWGS unit generates a constant flow of syngas fed to the methanol reactor. This implementation ensures the continuous operation of both the rWGS and methanol synthesis systems. By tuning the  $\text{H}_2/\text{CO}_2$  ratio and the reaction condition of rWGS, the generated syngas has the same composition as the syngas produced by steam reforming. We reduce the load of steam reforming by half and supplement the required syngas via electrification. In the above settings, only the electrolyzer responds to the dynamic energy market. As for chemical reaction systems such as rWGS, methanol synthesis, and SMR, they are unable to quickly modify their loads, and therefore, they are run in a steady mode. Within these chemical reaction systems, the continuous feed of streams (e.g.  $\text{CO}_2$  and  $\text{H}_2$ ), coupled with a steady operational mode, results in a constant production of intermediates (e.g. CO) and the final product (methanol)



**Figure 3 Schematic of flexible electrification coupled MeOH synthesis (ECMS) process.** A conventional methanol process sources hydrogen from SMR. We retrofit the process by adding a flexible electrolysis unit and a reverse water gas shift (rWGS) unit. The syngas produced from electrolysis and rWGS units partially replace the syngas produced by steam reforming. We harness electricity market dynamics by optimizing the electrolyzer operating mode every 15 minutes within a one-year planning horizon. A hydrogen storage facility provides the system

with flexibility by supplementing hydrogen when the electrolyzer is down; this absorbs excess hydrogen produced by the electrolyzer during the low energy price periods.

**Steam Reforming.** Currently, 95% of the hydrogen produced in the US is obtained using SMR<sup>30</sup>. After over 80 years of development, SMR has become the dominant industrial route to produce hydrogen and synthesis gas (mix of hydrogen and carbon monoxide)<sup>31</sup>. The following reaction takes place in a steam reformer, where high-temperature steam (700-1000°C) reacts with methane at 3-25 bar to produce hydrogen and carbon monoxide<sup>32</sup>. Figure 3 provides a simplified flowsheet diagram of SMR. The SMR unit simulated in this work is a two-step reforming process where a fired tubular reactor (primary reformer) is followed by an oxygen-fired adiabatic reformer (secondary reformer). The advantage of combining two reforming technologies is that the composition of the produced syngas can be adjusted to the most suitable condition for methanol synthesis. After removing sulfur, purified methane is compressed and mixed with steam. The high-pressure steam is obtained by heating the high-pressure water in the vaporizer. Natural gas and steam mixture is sent to a fired tubular reactor. The mixture of natural gas and steam passes through catalyst-filled tubes and contacts with nickel-aluminum-based catalyst, where it is converted into syngas. Because this reaction is highly endothermic, a portion of natural gas is combusted in a direct-fired furnace to provide the necessary heat for the primary reactor. To control the heat flow and the temperature of the reformer, several burners are arranged inside the furnace. Nearly 50% of the energy obtained from combustion of natural gas is used in the reforming reaction; the rest of the energy embedded in flue gas is typically utilized for pre-heating feedstocks or for generating steam. Typically, 35-40% of the natural gas is converted in this primary reactor at 800°C and 20 bar<sup>33</sup>. After leaving the primary reformer at 800°C<sup>34</sup>, the unreacted natural gas and syngas are fed to the secondary reformer, where the rest of the reaction is completed. The secondary reactor is an autothermal reforming (ATR) unit that consists of a burner, a combustion zone, and a catalyst bed. The feed stream is a mix of unreacted natural gas and steam with oxygen; the stream passes through the combustion zone, where partial oxidation takes place at 1000°C<sup>32</sup>. The stream then passes through the catalyst bed, where the final reaction takes place. Importantly, this adiabatic reformer enables the adjustment of the hydrogen/CO ratio of the synthesis gas, by tuning the amount of oxygen or the reaction temperature<sup>35</sup>.

**Methanol synthesis.** The synthesis gas is used for producing methanol at standard conditions (255°C and 50 bar<sup>36</sup>). We implemented a Lurgi reactor<sup>21</sup> using detailed energetics from the work by Grabow and Mavrikakis<sup>37</sup>. Here, we formulated a rigorous microkinetic model for the methanol

synthesis reaction over industrially relevant supported Cu catalysts. Using this model, we can directly predict methanol production based on different feed conditions. The microkinetic model includes a total of 22 surface intermediates, 8 gas phase species, and 49 elementary reactions steps; a detailed description of the model is provided in the SI. The methanol reactor is a tubular reactor with a cooling jacket, resembling a shell and tubular heat exchanger with catalyst on the tube side. Because methanol synthesis is exothermic, boiling water is circulated on the shell side for removing the excessive heat to maintain the desired reaction temperature. The control of the reaction temperature is achieved by manipulating the water pressure. The produced methanol is separated from the unreacted syngas in a flash tank. A purge stream is arranged to avoid accumulation in the system from the recycle stream. The rest of the recycle stream is compressed and mixed with the fresh stream and fed to the reactor. Finally, a stripper and a distillation column are deployed to obtain purified methanol.

**Electrolysis.** Water electrolysis was industrialized a hundred years ago and remains the most promising method for producing high-purity hydrogen<sup>38</sup>. Water electrolyzers can be classified into three main categories: alkaline electrolyzers, polymer electrolyte membrane (proton exchange membrane; PEM) electrolyzers, and solid oxide electrolyzers (SOE). The alkaline electrolyzer is relatively cheap, stable, and mature<sup>39</sup>. PEM has the advantage of producing high purity hydrogen, and it is also commercialized<sup>40</sup>. The SOE has high energy efficiency and can produce synthesis gas directly; however, this technology has not been commercialized<sup>41</sup>. Each electrolyzer has advantages/disadvantages regarding energy efficiency, stability, and cost.<sup>42</sup> However, in the context of the dynamic electricity markets that we study, one of the most critical features of the electrolyzer is flexibility. Specifically, an electrolyzer must be able to increase/reduce hydrogen production sufficiently fast to respond to electricity prices. Among the three types of electrolyzers, PEM has the flexibility that enables the system to deal fast transients; it takes less than a second to respond and settle to a prescribed set-point change<sup>43</sup>. Given the flexible nature of PEM, we select this technology. After splitting the deionized water into oxygen and hydrogen, the hydrogen is either fed to a Reverse Water Gas Shift (rWGS) unit or stored in a hydrogen tank. Typically, PEM electrolyzers operate at high pressure, with a hydrogen outlet pressure of around 30 bars<sup>44</sup>. This high-pressure hydrogen can be directly fed into the rWGS reactor without further compression. The deployed hydrogen tank is an above-ground, high-pressure vessel that operates at 16 bars. As shown in Figure 3, the valve reduces the pressure of hydrogen produced by the electrolyzer from 30 bars to 16 bars. The hydrogen with the lower pressure is then fed into the gas tank. Unlike liquid hydrogen tanks, which require refrigeration during storage, this process

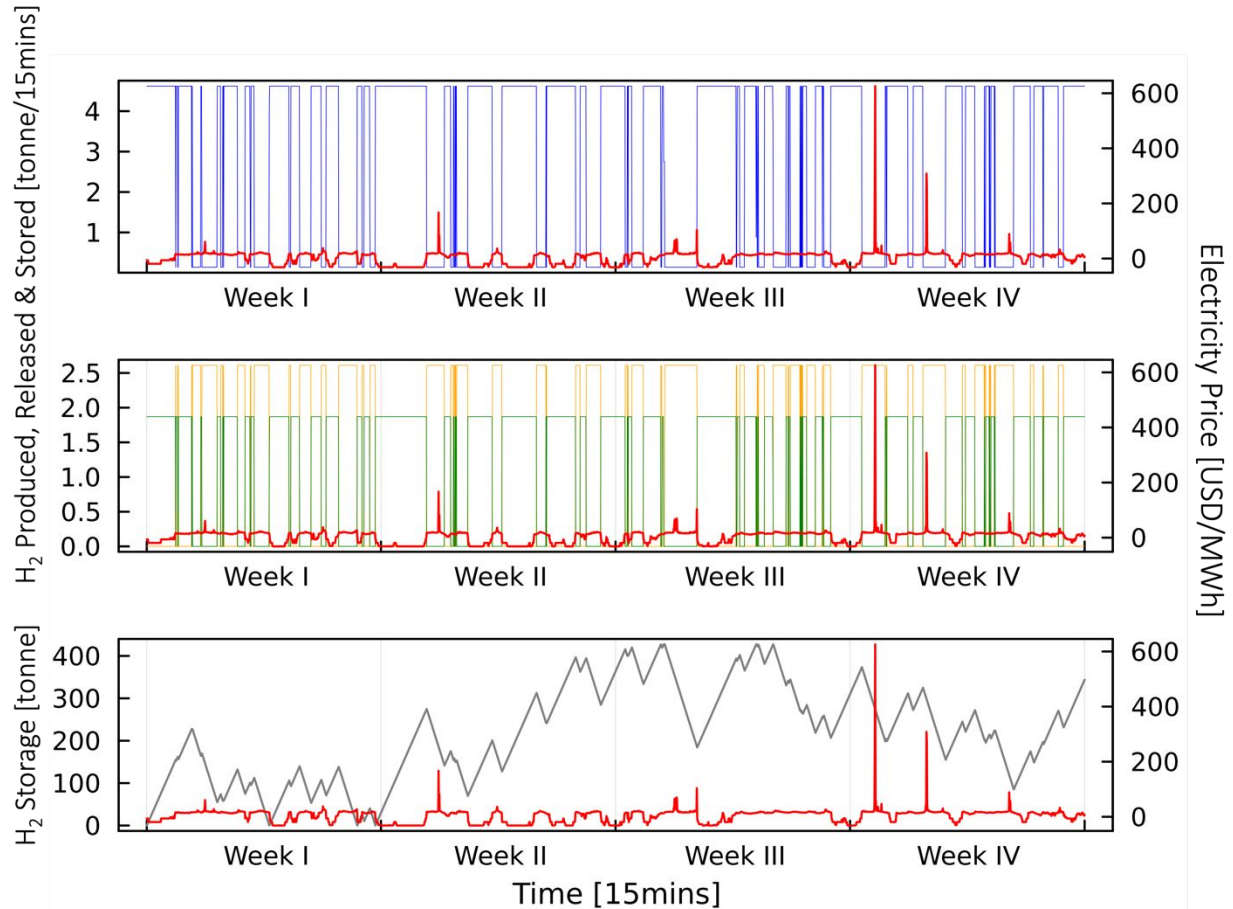
does not consume much energy. Furthermore, since the rWGS reactor operates at 16 bars as well, there is no need for additional compression work to compress the released hydrogen.

**Reverse Water Gas Shift (rWGS).** We retrofit the methanol plant by adding an electrification unit that is comprised of an electrolysis unit and of a rWGS unit. The goal of the electrification unit is to obtain the same syngas composition as the SMR unit. The composition of the synthesis gas is adjusted by manipulating the  $H_2/CO_2$  ratio and reaction temperature. In this work, the platinum-based catalyst is used, and the reaction temperature is set as  $900^\circ\text{C}$ . Because the rWGS reaction is mildly endothermic and the reactor is adiabatic<sup>35</sup>, the feeding stream is preheated to  $1078^\circ\text{C}$  (higher than the reaction temperature). After removing water, the product stream is compressed and mixed with synthesis gas produced by SMR. In contrast to the electrolyzer, the rWGS unit is operated under constant production mode, where the feedstock and product streams remain unchanged over time and the reactor runs continuously. The amount of synthesis gas produced by the electrification unit is obtained via optimization. The detailed optimization model is presented in the SI.

## Results

**Time-Varying Production Schedule.** Because most methanol plants in the US are located in Texas<sup>45</sup>, we consider real-time (15-min time interval) and day-ahead (1-hr time interval) electricity markets in the ERCOT market. To account for regional differences within this market, we explore prices in the Panhandle and in Houston. Detailed information on electricity markets is provided in the SI. In short, the Panhandle has a lower average electricity price and a higher negative price frequency than Houston. We also consider the flexible and inflexible operation modes for the electrolysis system. In the first mode, the electrolyzer adjusts hydrogen production to respond to the market dynamics. In the second mode, the electrolyzer does not respond to market dynamics and hydrogen production is kept constant. The production schedule of the flexible unit in the first month of 2020 (Panhandle, TX) is presented in Figure 4. As expected, hydrogen production drops down during the high price hours or even collapses to the minimum part-load (0.138 tons per 15 mins). When the electricity prices go down, the electrolyzer turns on at full capacity (4.61 tons per 15 mins). Because less hydrogen is produced during peak hours, hydrogen stored in the tank is consumed to meet the demand (2.75 tons per 15mins). During the off-peak hours, more hydrogen is produced than needed. The excess hydrogen (1.87 tons per 15mins) is stored in the tank. The storage level goes down during peak hours since the stored gas is consumed; during the off-peak

hours, the gas in the tank builds up. The tank capacity for this scenario was obtained via optimization and was found to be 427 tons. The production profiles of other case studies can be found in the SI, and similar patterns are observed.



**Figure 4** Real-time market energy price (red), hydrogen produced (blue) /released (yellow)/ stored (green), and the gas in the storage tank (grey) for the flexible electrification system. Panhandle, TX in Jan. 2020.

**Economic Viability.** We considered a couple of operational modes (flexible and non-flexible) under a couple of electricity markets (RTM and DAM) and at a couple of geographical locations in Texas (Houston and Panhandle). As such, we use our computational framework to explore 8 possible scenarios. In Figure 5, we summarize the economic results for the 8 scenarios. The total annual cost (TAC) consists of annualized capital expenditure of hydrogen tank, electrolyzer stack and balance of plant (BOP), rWGS unit, electricity cost, CO<sub>2</sub> purchase cost, and deionized water cost. We calculated the annualized capital investment by multiplying the capital cost of a piece of equipment with an annualized factor, which depends on the interest rate and the plant lifespan. The SI provides a comprehensive overview of the economic parameters involved. The cost of

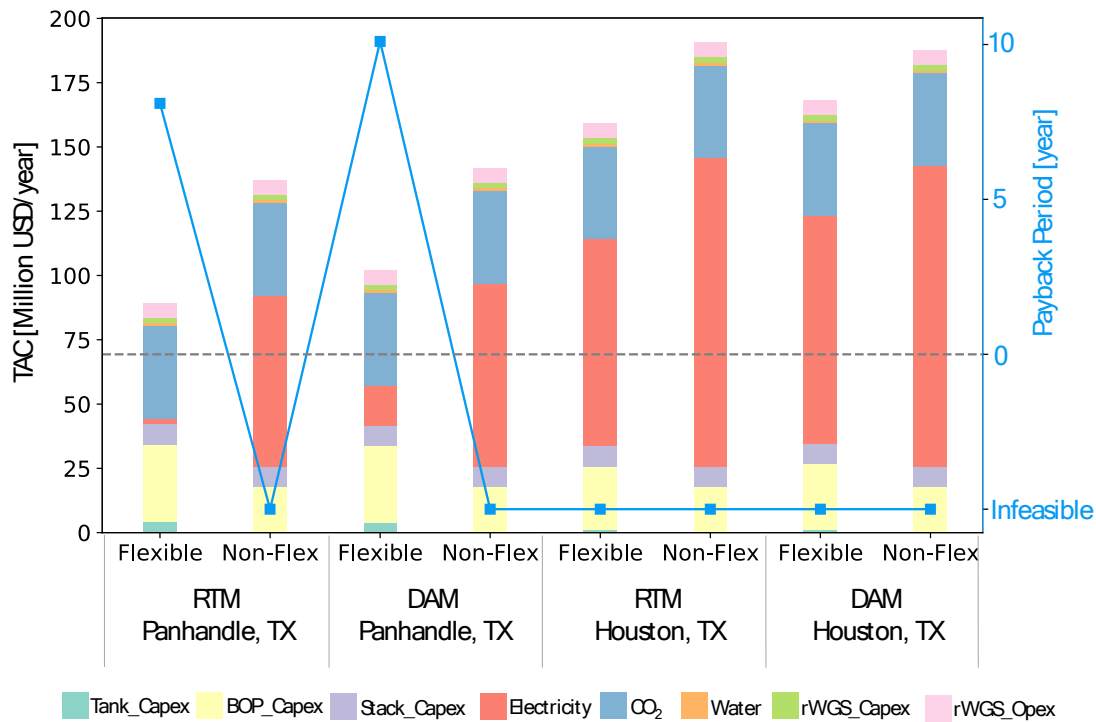
CO<sub>2</sub> and deionized water purchases, on the other hand, is dependent on market prices of these commodities and the yearly consumption of CO<sub>2</sub> and water by the facility. The price of CO<sub>2</sub> varies based on its source, with CO<sub>2</sub> from coal-fired power plants estimated at 47 USD per ton and CO<sub>2</sub> from natural gas power plants estimated at 75 USD per ton<sup>23</sup>. Obtaining CO<sub>2</sub> from an ethanol fermentation plant is comparatively less expensive, with a CO<sub>2</sub> price of around 30 USD per ton<sup>46</sup>. In this study, we assumed that CO<sub>2</sub> was obtained from a coal-fired power plant. A sensitivity analysis was carried out (see next section) to evaluate the impact of CO<sub>2</sub> prices on overall economics.

Figure 5 shows the cost breakdowns of non-flexible and flexible systems. We can see that the electricity cost contributes 60% of the TAC in the non-flexible case. On the other hand, the electricity cost *almost collapses to zero* when the system is flexible; specifically, the flexible electrolyzer takes advantage of low or negative electricity prices and produces excess hydrogen to be used at peak hours. Using electricity with negative prices creates a revenue stream that nearly offsets electricity costs. Negative prices are associated with excess power supply in the grid (e.g., common in markets with high wind penetration); the flexible methanol process helps absorb this excess power and this service is remunerated by the grid. Our results also revealed interesting trade-offs between capital investment and operational flexibility. The annualized investment cost of the flexible unit (34 million USD) is twice that of the non-flexible unit (17 million USD); however, 65 million USD of electricity costs per year can be saved via flexibility. Similar patterns are observed in the other scenarios.

The average price of RTM is lower than that of DAM; moreover, DAM has a lower negative price frequency than RTM. Therefore, the TAC of the third scenario is 12 million USD higher than the TAC of the first scenario. This gap mainly results from the electricity cost. This pattern implies the importance of participating in the proper electricity market, which affects the expected level of system flexibility. Given the relatively high electricity price, the TAC of the last four scenarios is in the range of 160-180 million USD. The electricity cost of the fifth scenario is even higher than the TAC of the first scenario. Being flexible can still lower the overall production cost to some extent in this scenario. For example, the TAC of the fifth scenario is 30 million USD lower than the TAC of the sixth scenario. However, because the negative price frequency of RTM in Houston is almost zero, there is no strong incentive to produce hydrogen via electrolysis.

In Figure 5, we also present the payback period for each scenario. Only the first and third scenarios (with flexible systems) are economically viable/feasible, and the corresponding

payback periods are 8-10 years. The non-flexible system is not economically viable in any of the scenarios. Specifically, even with an average RTM price in Panhandle, TX (12 USD/MWh, which is 25% lower than the Texas average), the non-flexible system is not viable. This again highlights the importance of being flexible and exploiting price dynamics. The techno-economic analysis focuses on augmenting an existing methanol plant (that embeds an SMR unit) with an electrification unit. The deployment of the electrification unit can reduce the cost of the SMR, and this reduction can be seen as a revenue stream. The SMR cost reduction is obtained via reductions on the use of natural gas, electricity, water, and oxygen. We found that reducing the capacity of SMR by 50% leads to a 131 million USD cost reduction. After considering the operational cost of the electrification units, the annual cost reduction of the first and third scenarios are 60 million USD and 47 million USD, respectively. This implies that, under certain scenarios, the flexible electrification unit can produce synthesis gas at a lower cost than SMR. Specifically, this occurs when the electricity market provides sufficient incentives (sufficiently low average prices and sufficiently high frequency of negative prices).



**Figure 5** Total annual cost (TAC) breakdown and payback period for flexible and non-flexible systems.

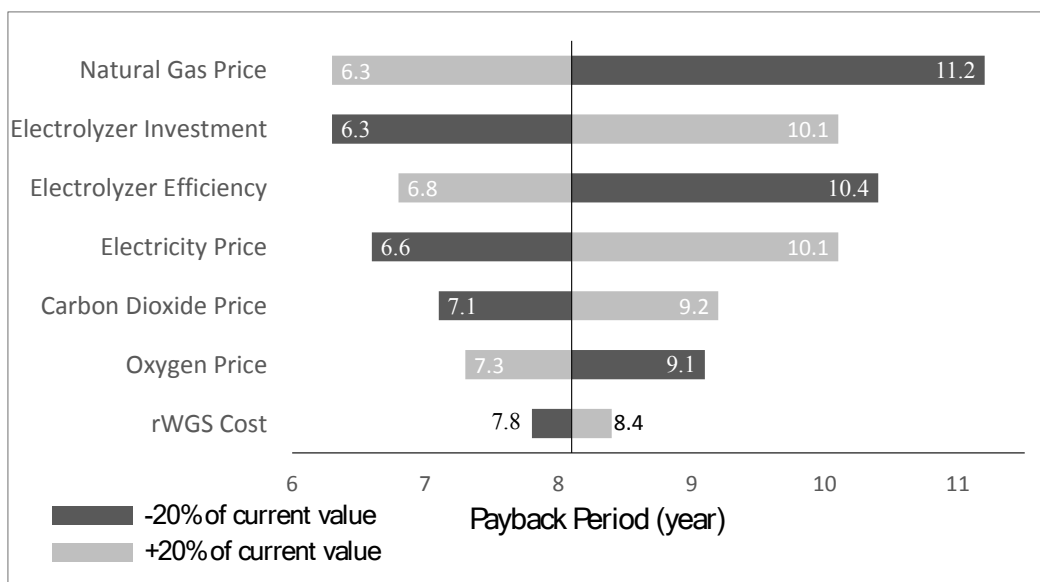
**Sensitivity Analysis.** We used sensitivity analysis to explore the impact of techno-economic parameters on the viability of the system (see Figure 6). We perturb the values of each parameter by 20% and analyze how the payback period changes. We recall that partially replacing SMR with



electrolysis can lead to revenue if natural gas prices are high; therefore, the flexible electrification unit has shorter payback periods when natural gas prices are high. This highlights that the methanol process benefits from having a dual system that includes SMR and electrolysis. We also note that the production of oxygen by the electrolyzer can create a revenue stream; as such, the higher the oxygen prices, the shorter the payback period.

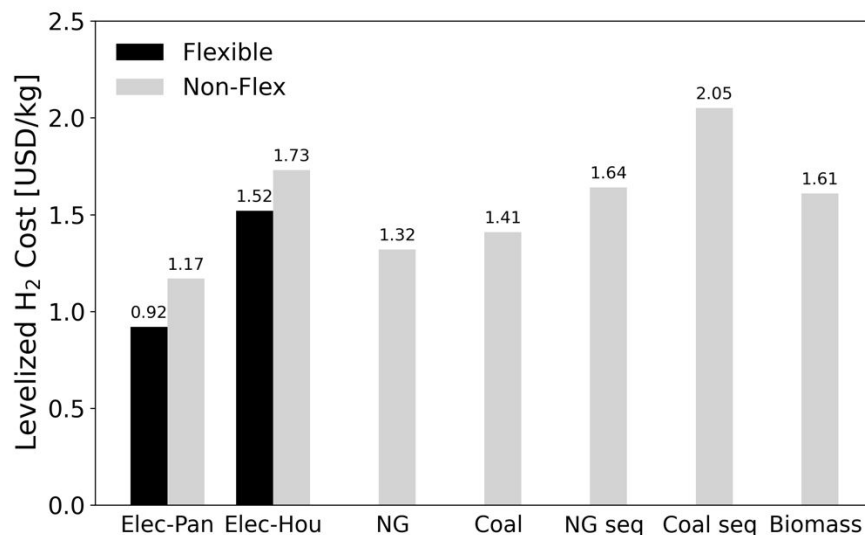
The second and the third factors are related to the capital cost and the efficiency of the electrolyzer. Surprisingly, we found that lowering the capital cost of the electrolyzer leads to higher benefits than increasing its efficiency. Lowering equipment costs can potentially result from lowering of material costs (by finding new and inexpensive materials) and/or from mass manufacturing and deployment of these systems (incentivized by growing interest in decarbonization). For instance, material costs of electrolyzer equipment (specifically the catalyst-coated membrane (CCM), porous transport layer (PLT), and bipolar plates) significantly impact overall stack costs. The CCM, created by depositing layers of catalysts on both sides of a membrane to form the cathode and anode layers where the electrochemical reaction occurs, accounts for 40% of the stack cost. The PLT, made from sintered titanium, is responsible for transporting reactant water to the catalyst layers and removing produced oxygen gas, contributing 20% to the stack cost. The bipolar plates, made of stainless steel, are designed for distributing fuel gas and air and conducting electrical current, also contribute 20% to the stack cost. The discovery of new materials to reduce the cost of these stack components can thus improve the overall viability of the methanol process.

The economic viability of the system is sensitive to the location and the type of electricity market (which affects overall electricity price). However, it is important to note that using the average price as the only metric is misleading, as economic incentives originate frequency of low and negative prices. We also found that a 20% decrease in CO<sub>2</sub> prices shortens the payback period by one year, making the system more profitable; as such, access to low-cost CO<sub>2</sub> sources and carbon sequestration credits can further improve the economic viability of the methanol process.

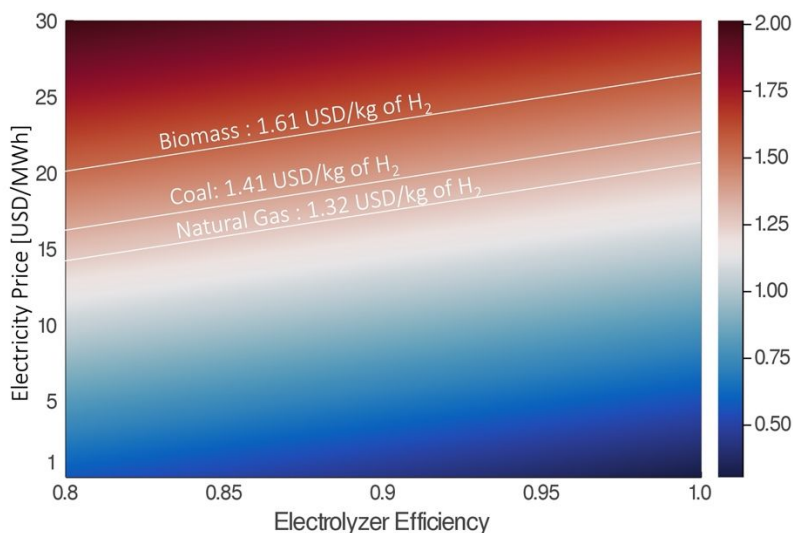


**Figure 6 Sensitivity analysis for the flexible electrification coupled methanol synthesis system.**

The proposed flexible electrification unit can be applied to different hydrogen-based chemical processes. As such, we also explored the levelized cost of hydrogen (LCOH) that can be obtained under different electricity markets and compared this to the LCOH obtained via SMR. In Figure 7, we compare the LCOH using six technologies. The LCOH obtained from fossil fuels or biomass ranges from 1.32 to 2.05 USD/kg<sup>47</sup>. Using natural gas via SMR is the cheapest option (LCOH is 1.32 USD/kg). We compare this with the LCOHs obtained via flexible electrification (RTM of Panhandle and Houston). The flexible electrification in the Panhandle has the lowest LCOH (0.92 USD/kg), which is 31% lower than the LCOH of SMR. The LCOH of flexible electrification in Houston (1.52 USD/kg) is 15% higher than that of SMR (this is due to the less favorable electricity market conditions in Houston). Interestingly, however, the LCOH of the flexible system in Houston is lower than that of biomass. We also found that the LCOH of the flexible systems in Houston and in the Panhandle are lower than that of the inflexible counterparts (12% and 20%, respectively).



**Figure 7** Levelized cost of hydrogen for different energy sources, including electrification, natural gas (NG), coal, natural gas with CO<sub>2</sub> sequestration (NG seq), Coal with CO<sub>2</sub> sequestration (Coal seq), and biomass.



**Figure 8** Levelized cost of hydrogen (LCOH) as a function of electricity price and electrolyzer efficiency

The economic viability of the proposed system is sensitive to the locations and the type of energy markets in which it participates. To determine critical electricity prices and energy efficiency that make non-flexible systems competitive, we define the electrification LCOH as a function of the average electricity price and of the energy efficiency. As shown in Figure 8, given the current PEM electrolyzer efficiency (80%), to have the same LCOH as SMR, the average electricity price has to be lower than 14 USD/MWh. Therefore, in a location such as Kansas, where the average

electricity price is 13.7 USD/MWh (in 2020), the proposed electrification system is the most economical option for producing hydrogen. The average electricity price in Minnesota (in 2020) was 17 USD/MWh and is thus not viable. We also found that the LCOH of the electrified unit cannot compete with the LCOH of SMR unless the electrolyzer efficiency is higher than 0.92. In future work, we will aim to conduct a similar analysis, but we will also take into account different degrees of market volatility that can make electrification viable.

**Discussion.** We proposed a computational framework for determining optimal sizing and operations electrified units that provide synthesis gas to a methanol synthesis process. The economic viability of such a system is affected by the local energy market, the type of energy market that it participates in, and the operation mode of the system (flexible and inflexible). We found that it is economically viable to retrofit an existing methanol plant with a flexible electrification unit under electricity markets that have sufficiently low average prices and sufficiently high frequency of negative prices. Our results also indicate that hydrogen can be produced at a lower cost than SMR with flexible electrolysis units. Our results also indicate that flexibility is a key asset that needs to be considered in process design. For instance, we find that participating in the RTM consistently outperforms participation in the DAM. To take advantage of RTM volatility, the proposed electrification system is required to switch its production load every 15mins. We also observed that the economy of this system is more sensitive to the electrolyzer equipment cost than its energy efficiency; this suggests that reducing the manufacturing cost of electrolyzer is more promising than improving its efficiency.

The proposed flexible electrification unit and computational approach can be applied to different hydrogen-based chemical production systems. Specifically, our optimization framework allows us to estimate the levelized production cost of hydrogen as a function of the time-varying energy prices (from different markets). As such, we can use these tools to determine viability of electrifying different facilities and also to understand how increasing market volatility (expected under higher share of renewables) can create incentives for electrification. Our work assumed that we have perfect information of electricity market. In the future, we will develop statistical tools to predict the electricity market and propose advanced control models for harnessing the flexibility of the energy market at most. In addition, we will investigate potential revenue sources for flexible units that can result from the provision of electricity demand flexibility and from sales of hydrogen in external markets (e.g., for energy storage). Moreover, it is necessary to conduct a more

comprehensive study on the economic viability of electrified processes in different markets/regions of the United States and of the world.

Deploying technologies that can adjust their power demands can bring substantial benefits to the power grid. Specifically, such technologies can respond to market signals to decrease/increase power demands to help absorb fluctuations in the grid that result from adoption of wind/solar power. The mass deployment of electrified technologies such as the one considered here, however, will require careful analysis on power grid needs in terms of generation capacity and transmission network infrastructure. This is an important topic of future work.

**Acknowledgements.** We acknowledge support from NSF CAREER award [CBET-1748516](#). This work was also partially supported by DOE-BES, Office of Science, Catalysis Science Program, under grant #: DE-FG02-05ER15731.

## References

- (1) The White House. FACT SHEET: President Biden Sets 2030 Greenhouse Gas Pollution Reduction Target Aimed at Creating Good-Paying Union Jobs and Securing U.S. Leadership on Clean Energy Technologies. <https://www.whitehouse.gov/briefing-room/statements-releases/2021/04/22/fact-sheet-president-biden-sets-2030-greenhouse-gas-pollution-reduction-target-aimed-at-creating-good-paying-union-jobs-and-securing-u-s-leadership-on-clean-energy-technologies/>.
- (2) National Academies of Sciences Engineering and Medicine. *Accelerating Decarbonization of the U.S. Energy System*, 2021.
- (3) The White House. Biden-Harris Administration Announces \$6 Billion To Drastically Reduce Industrial Emissions and Create Healthier Communities. <https://www.energy.gov/articles/biden-harris-administration-announces-6-billion-drastically-reduce-industrial-emissions>.
- (4) EIA. 2018 Manufacturing Energy Consumption Survey. *Surv. Data-Energy Consum. as a fuel. U.S. Energy Inf. Adm.* **2021**.
- (5) Van Geem, K. M.; Galvita, V. V.; Marin, G. B. Making Chemicals with Electricity. *Science (80-. )*. **2019**, *364* (6442), 734–735. <https://doi.org/10.1126/science.aax5179>.
- (6) Schiffer, Z. J.; Manthiram, K. Electrification and Decarbonization of the Chemical Industry. *Joule* **2017**, *1* (1), 10–14. <https://doi.org/10.1016/j.joule.2017.07.008>.

- (7) Wismann, Sebastian T., Jakob S. Engbæk, Søren B. Vendelbo, Flemming B. Bendixen, Winnie L. Eriksen, Kim Aasberg-Petersen, Cathrine Frandsen, Ib Chorkendorff, and P. M. M. Electrified Methane Reforming: A Compact Approach to Greener Industrial Hydrogen Production. *Science* (80-. ). **2019**, *364* (6442), 756–759.
- (8) Steeneveldt, R.; Berger, B.; Torp, T. A. *CO<sub>2</sub> Capture and Storage*, 2006; Vol. 84. <https://doi.org/10.1205/cherd05049>.
- (9) Spath, Pamela L., and M. K. M. Life Cycle Assessment of Hydrogen Production via Natural Gas Steam Reforming. **2000**, No. *NREL* (TP), 570–27637.
- (10) The White House. FACT SHEET: Biden-Harris Administration Advances Cleaner Industrial Sector to Boost American Manufacturing and Cut Emissions. <https://www.whitehouse.gov/briefing-room/statements-releases/2023/03/08/fact-sheet-biden-harris-administration-advances-cleaner-industrial-sector-to-boost-american-manufacturing-and-cut-emissions/>.
- (11) Guerra, O. J.; Eichman, J.; Denholm, P. Optimal Energy Storage Portfolio for High and Ultrahigh Carbon-Free and Renewable Power Systems. *Energy Environ. Sci.* **2021**, *14* (10), 5132–5146. <https://doi.org/10.1039/d1ee01835c>.
- (12) Hieminga, G.; Patterson, W. Energy Outlook 2021. *Bipartisan Policy Cent.* **2021**, *2021* (January), 1–22.
- (13) Götz, M.; Lefebvre, J.; Mörs, F.; McDaniel Koch, A.; Graf, F.; Bajohr, S.; Reimert, R.; Kolb, T. Renewable Power-to-Gas: A Technological and Economic Review. *Renew. Energy* **2016**, *85*, 1371–1390. <https://doi.org/10.1016/j.renene.2015.07.066>.
- (14) International Energy Agency. Status of Power System Transformation 2019: Power System Flexibility. *OECD Publ.* **2019**, 1–26.
- (15) Varone, A.; Ferrari, M. Power to Liquid and Power to Gas: An Option for the German Energiewende. *Renew. Sustain. Energy Rev.* **2015**, *45*, 207–218. <https://doi.org/10.1016/j.rser.2015.01.049>.
- (16) Zhang, H.; Desideri, U. Techno-Economic Optimization of Power-to-Methanol with Co-Electrolysis of CO<sub>2</sub> and H<sub>2</sub>O in Solid-Oxide Electrolyzers. *Energy* **2020**, *199*, 117498. <https://doi.org/10.1016/j.energy.2020.117498>.
- (17) Bergins, C.; Tran, K.; Koytsoumpa, E.; Kakaras, E.; Buddenberg, T.; Sigurbjörnsson, Ó. Power to Methanol Solutions for Flexible and Sustainable Operations in Power and Process Industries Mitsubishi Hitachi Power Systems Europe GmbH , Germany \* Carbon Recycling International , Iceland. **2015**, 1–18.
- (18) Tzanetis, K. F.; Posada, J. A.; Ramirez, A. Analysis of Biomass Hydrothermal Liquefaction and Biocrude-Oil Upgrading for Renewable Jet Fuel Production: The Impact

- of Reaction Conditions on Production Costs and GHG Emissions Performance. *Renew. Energy* **2017**, *113*, 1388–1398. <https://doi.org/10.1016/j.renene.2017.06.104>.
- (19) Hank, C.; Gelpke, S.; Schnabl, A.; White, R. J.; Full, J.; Wiebe, N.; Smolinka, T.; Schaadt, A.; Henning, H. M.; Hebling, C. Economics & Carbon Dioxide Avoidance Cost of Methanol Production Based on Renewable Hydrogen and Recycled Carbon Dioxide-Power-to-Methanol. *Sustain. Energy Fuels* **2018**, *2* (6), 1244–1261. <https://doi.org/10.1039/c8se00032h>.
- (20) Mbatha, S.; Everson, R. C.; Musyoka, N. M.; Langmi, H. W.; Lanzini, A.; Brilman, W. Power-to-Methanol Process: A Review of Electrolysis, Methanol Catalysts, Kinetics, Reactor Designs and Modelling, Process Integration, Optimisation, and Techno-Economics. *Sustain. Energy Fuels* **2021**, *5* (14), 3490–3569. <https://doi.org/10.1039/d1se00635e>.
- (21) Dieterich, V.; Buttler, A.; Hanel, A.; Spliethoff, H.; Fendt, S. Power-to-Liquid via Synthesis of Methanol, DME or Fischer–Tropsch-Fuels: A Review. *Energy Environ. Sci.* **2020**, *13* (10), 3207–3252. <https://doi.org/10.1039/d0ee01187h>.
- (22) Zhang, H.; Wang, L.; Van herle, J.; Maréchal, F.; Desideri, U. Techno-Economic Comparison of Green Ammonia Production Processes. *Appl. Energy* **2020**, *259* (October 2019), 114135. <https://doi.org/10.1016/j.apenergy.2019.114135>.
- (23) González-Garay, A.; Frei, M. S.; Al-Qahtani, A.; Mondelli, C.; Guillén-Gosálbez, G.; Pérez-Ramírez, J. Plant-to-Planet Analysis of CO<sub>2</sub>-Based Methanol Processes. *Energy Environ. Sci.* **2019**, *12* (12), 3425–3436. <https://doi.org/10.1039/c9ee01673b>.
- (24) Davis, S. J.; Lewis, N. S.; Shaner, M.; Aggarwal, S.; Arent, D.; Azevedo, I. L.; Benson, S. M.; Bradley, T.; Brouwer, J.; Chiang, Y. M.; Clack, C. T. M.; Cohen, A.; Doig, S.; Edmonds, J.; Fennell, P.; Field, C. B.; Hannegan, B.; Hodge, B. M.; Hoffert, M. I.; Ingersoll, E.; Jaramillo, P.; Lackner, K. S.; Mach, K. J.; Mastrandrea, M.; Ogden, J.; Peterson, P. F.; Sanchez, D. L.; Sperling, D.; Stagner, J.; Trancik, J. E.; Yang, C. J.; Caldeira, K. Net-Zero Emissions Energy Systems. *Science (80-. )*. **2018**, *360* (6396). <https://doi.org/10.1126/science.aas9793>.
- (25) Shao, Y.; Zavala, V. M. Space-Time Dynamics of Electricity Markets Incentivize Technology Decentralization. *Comput. Chem. Eng.* **2019**, *127*, 31–40. <https://doi.org/10.1016/j.compchemeng.2019.05.005>.
- (26) The International Market Analysis Research and Consulting Group. Methanol Market: Global Industry Trends, Share, Size, Growth, Opportunity and Forecast 2022-2027. **2021**.
- (27) Seel, J.; Millstein, D.; Mills, A.; Bolinger, M.; Wiser, R. Plentiful Electricity Turns Wholesale Prices Negative. *Adv. Appl. Energy* **2021**, *4* (May), 100073.

- <https://doi.org/10.1016/j.adapen.2021.100073>.
- (28) Electricity Markets and Policy Group, Lawrence Berkeley National Laboratory. The Renewables and Wholesale Electricity Prices (ReWEP) Tool  
<https://emp.lbl.gov/renewables-and-wholesale-electricity-prices-rewep>.
- (29) ERCOT Market Information <https://www.ercot.com/mktinfo>.
- (30) Office of Fossil Energy; Department of Energy; US. Hydrogen Strategy Enabling A Low-Carbon Economy. **2020**, *24*.
- (31) Murkin, C.; Brightling, J. Eighty Years of Steam Reforming. *Johnson Matthey Technol. Rev.* **2016**, *60* (4), 263–269. <https://doi.org/10.1595/205651316X692923>.
- (32) Korobitsyn, M. A.; Van Berkel, F. P. F.; Christie, G. M. SOFC AS A GAS SEPARATOR Synthesis Gas Production. **2000**, No. December.
- (33) Aasberg-petersen, B. K.; Nielsen, C. S.; Dybkjær, I.; Perregaard, J. Large Scale Methanol Production from Natural Gas.
- (34) Thomsen, S. G.; Han, P. A.; Loock, S.; Ernst, W. The First Industrial Experience with the Haldor Topsøe Exchange Reformer. *Ammon. Plant Saf. Relat. Facil.* **2006**, *47*, 259–266.
- (35) Baltrusaitis, J.; Luyben, W. L. Methane Conversion to Syngas for Gas-to-Liquids (GTL): Is Sustainable CO<sub>2</sub> Reuse via Dry Methane Reforming (DMR) Cost Competitive with SMR and ATR Processes? *ACS Sustain. Chem. Eng.* **2015**, *3* (9), 2100–2111.  
<https://doi.org/10.1021/acssuschemeng.5b00368>.
- (36) Lee, S. Methanol Synthesis Technology. **1989**.
- (37) Grabow, L. C.; Mavrikakis, M. Mechanism of Methanol Synthesis on Cu through CO<sub>2</sub> and CO Hydrogenation. *ACS Catal.* **2011**, *1* (4), 365–384. <https://doi.org/10.1021/cs200055d>.
- (38) Kreuter, W.; Hofmann, H. Electrolysis: The Important Energy Transformer in a World of Sustainable Energy. *Int. J. Hydrogen Energy* **1998**, *23* (8), 661–666.  
[https://doi.org/10.1016/S0360-3199\(97\)00109-2](https://doi.org/10.1016/S0360-3199(97)00109-2).
- (39) Ursúa, A.; Gandía, L. M.; Sanchis, P. Hydrogen Production from Water Electrolysis: Current Status and Future Trends. *Proc. IEEE* **2012**, *100* (2), 410–426.  
<https://doi.org/10.1109/JPROC.2011.2156750>.
- (40) Barbir, F. PEM Electrolysis for Production of Hydrogen from Renewable Energy Sources. *Sol. Energy* **2005**, *78* (5), 661–669. <https://doi.org/10.1016/j.solener.2004.09.003>.
- (41) Chi, J.; Yu, H. Water Electrolysis Based on Renewable Energy for Hydrogen Production. *Cuihua Xuebao/Chinese J. Catal.* **2018**, *39* (3), 390–394. [https://doi.org/10.1016/S1872-2067\(17\)62949-8](https://doi.org/10.1016/S1872-2067(17)62949-8).
- (42) Sapountzi, F. M.; Gracia, J. M.; Weststrate, C. J. (Kee, J.; Fredriksson, H. O. A.; Niemantsverdriet, J. W. (Hans. Electrocatalysts for the Generation of Hydrogen, Oxygen



- and Synthesis Gas. *Prog. Energy Combust. Sci.* **2017**, *58*, 1–35.  
<https://doi.org/10.1016/j.pecs.2016.09.001>.
- (43) Eichman, J.; Harrison, K.; Peters, M.; Eichman, J.; Harrison, K.; Peters, M. Novel Electrolyzer Applications : Providing More Than Just Hydrogen Novel Electrolyzer Applications : Providing More Than Just Hydrogen. *NREL Rep.* **2014**, No. September, 1–24.
- (44) Hancke, R.; Holm, T.; Ulleberg, Ø. The Case for High-Pressure PEM Water Electrolysis. *Energy Convers. Manag.* **2022**, *261* (April).  
<https://doi.org/10.1016/j.enconman.2022.115642>.
- (45) Ameen, N.; Tsai, K. New methanol plants expected to increase industrial natural gas use through 2020 <https://www.eia.gov/todayinenergy/detail.php?id=38412> (accessed Feb 12, 2022).
- (46) Sanchez, D. L.; Johnson, N.; McCoy, S. T.; Turner, P. A.; Mach, K. J. Near-Term Deployment of Carbon Capture and Sequestration from Biorefineries in the United States. *Proc. Natl. Acad. Sci. U. S. A.* **2018**, *115* (19), 4875–4880.  
<https://doi.org/10.1073/pnas.1719695115>.
- (47) DOE. Enabling A Low-Carbon Economy. *Washington, DC 20585* **2020**, 24.